



BEDIENUNGSANLEITUNG

SERVICEWAGEN

MIT ROLLEN

SICHERHEITSHINWEISE



Lesen und befolgen Sie die Informationen im Benutzerhandbuch.



Bitte halten Sie Kinder aus Sicherheitsgründen von kleinen Komponenten fern.



Das Produkt soll in einer trockenen Umgebung verwendet werden.



Bitte beachten Sie, dass Holz nicht kratzfest ist.



Wasserflecken und Flecken soll rechtzeitig gereinigt werden.



Platzieren Sie keine übergewichtigen Gegenstände.



Bitte behandeln Sie Holz und anderes Zubehör sachgemäß.

— HAFTUNGSAUSSCHLUSS —





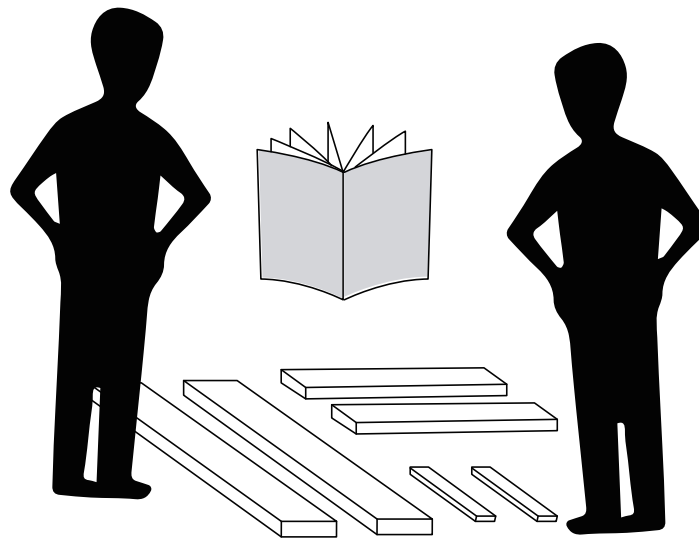



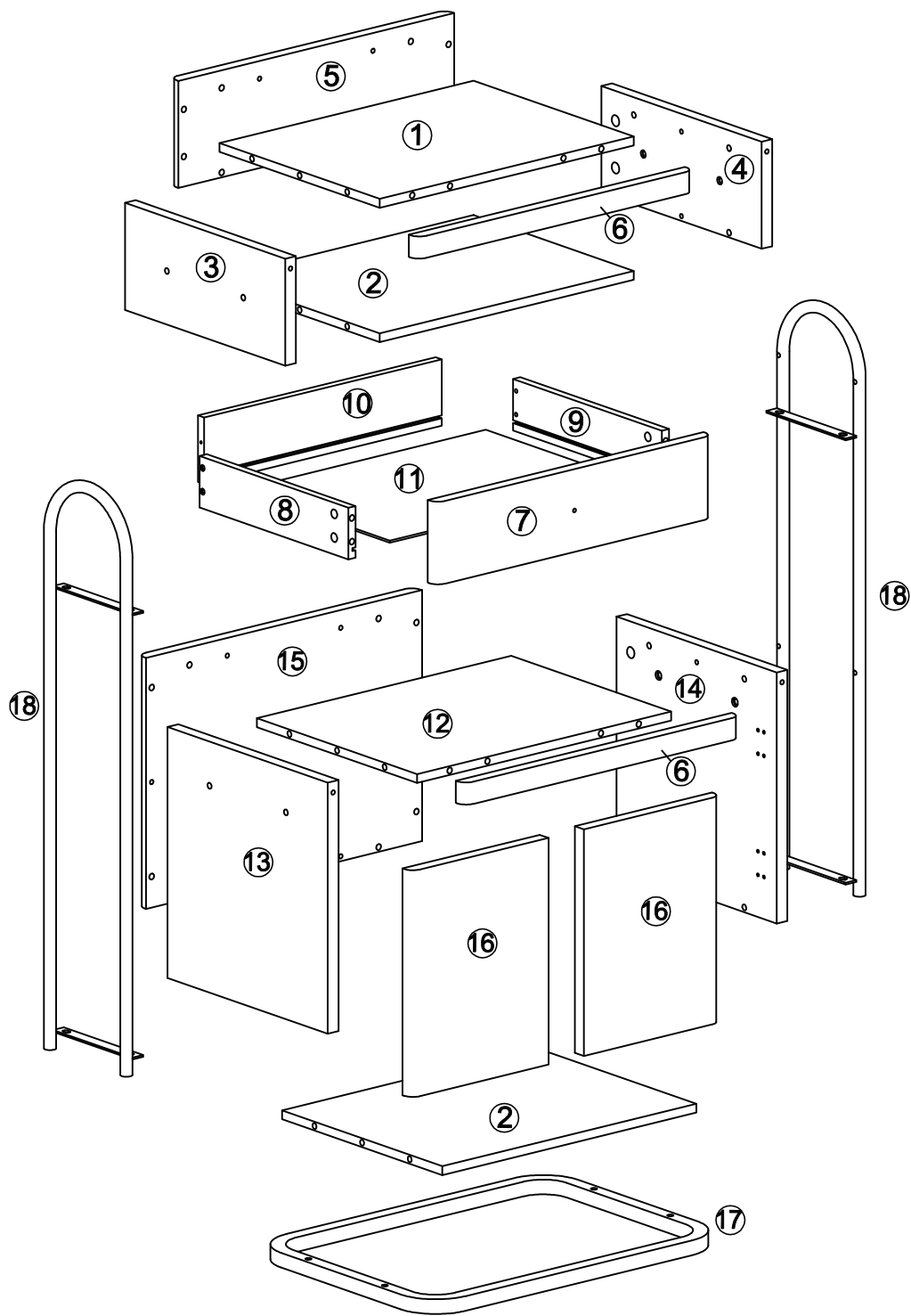







Wir bitten Sie, diese Anleitung vollständig zu lesen, bevor Sie den Artikel zusammenbauen und in Betrieb nehmen. Wir sind nicht und können nicht für Schäden oder Verletzungen verantwortlich gemacht werden, die durch unsachgemäße oder unsichere Verwendung des Artikels entstehen. Wir lehnen ausdrücklich die Verantwortung für Körperverletzungen oder Sachschäden ab, die bei einer Verwendung auftreten können, die nicht den geltenden Bundes-, Landes- oder lokalen Gesetzen oder Verordnungen entspricht. Bitte bewahren Sie dieses Handbuch für zukünftige Bezugnahme auf.

INSTALLATIONSVORBEREITUNG



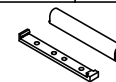





- Bitte bereiten Sie einen Teppich oder eine Matte vor, um Ihren Boden zu schützen. Sie müssen alle Zubehörteile auslegen.
- Bitte bereiten Sie ein Paar Handschuhe vor, um Kratzer durch scharfes Holzsägemehl zu vermeiden, das während der Installation auftreten kann.
- Bitte öffnen Sie alle Kartons, um zu überprüfen, ob das Zubehör vollständig und in gutem Zustand ist.
- Die Box enthält einige kleine Komponenten, bitte platzieren Sie sie vor der Installation richtig, um sie von Kindern fernzuhalten und die Sicherheit zu gewährleisten.
- Wenn Sie Elektrowerkzeuge verwenden müssen, um dieses Produkt zu installieren, stellen Sie bitte die Geschwindigkeit im Voraus auf niedrige Geschwindigkeit ein.
- Richten Sie bei der Installation bitte alle Löcher aus, bevor Sie alle Schrauben festziehen.

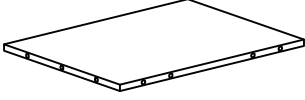
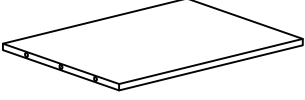
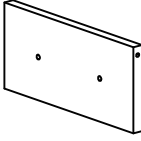
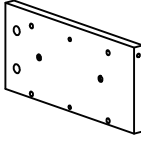
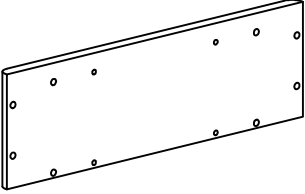

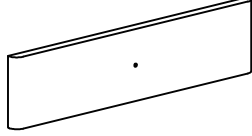
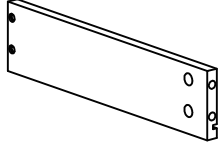
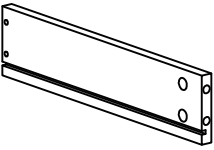
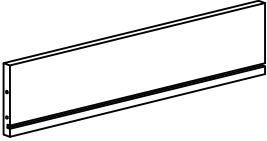
A	X40+1	B	X40+1	C	X26+1	D	X29+1	E	X4+1	F	X1
											
φ6X35mm	φ15X10mm	φ6X30mm	3.5X14mm	φ4X35mm	M4X45X45mm						
G	X1	H	X1	I	X1+1	J	X8+1	K	X12+1	L	X1
											
	φ31X28mm	M4X22mm	M6X12mm	M6X28mm	60X16mm						
M	X2	O	X4	P	X4	Q	X1				
											
	M8XØ50mm			φ20							

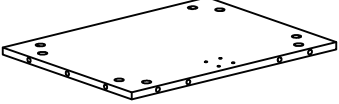
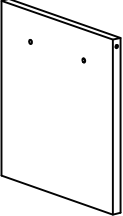
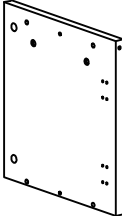
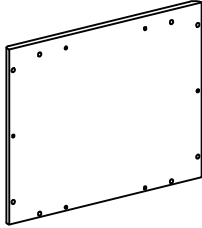
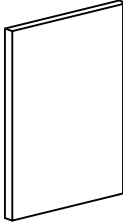
ZUBEHÖRTEILE

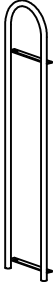
<p>1 x1</p>  <p>430x323 mm</p>	<p>2 x2</p>  <p>430x323 mm</p>	<p>3 x1</p>  <p>323x145 mm</p>	<p>4 x1</p>  <p>323x145 mm</p>
<p>5 x1</p>  <p>467x145 mm</p>	<p>6 x2</p>  <p>467x30 mm</p>	<p>7 x1</p>  <p>467x112 mm</p>	<p>8 x1</p>  <p>300x70 mm</p>
<p>9 x1</p>  <p>300x70 mm</p>	<p>10 x1</p>  <p>402x90 mm</p>	<p>11 x1</p>  <p>411x296 mm</p>	<p>12 x1</p>  <p>430x323 mm</p>
<p>13 x1</p>  <p>340x323 mm</p>	<p>14 x1</p>  <p>340x323 mm</p>	<p>15 x1</p>  <p>467x340 mm</p>	<p>16 x2</p>  <p>307x231 mm</p>
<p>17 x1</p>  <p>503x360 mm</p>	<p>18 x2</p>  <p>785x170 mm</p>		



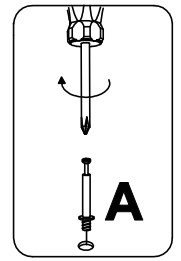
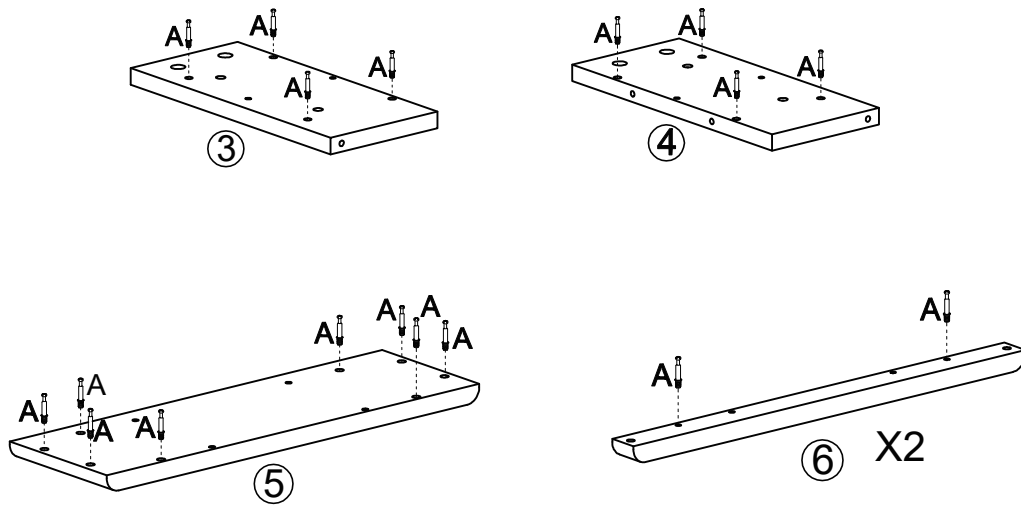

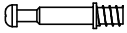
Step 01

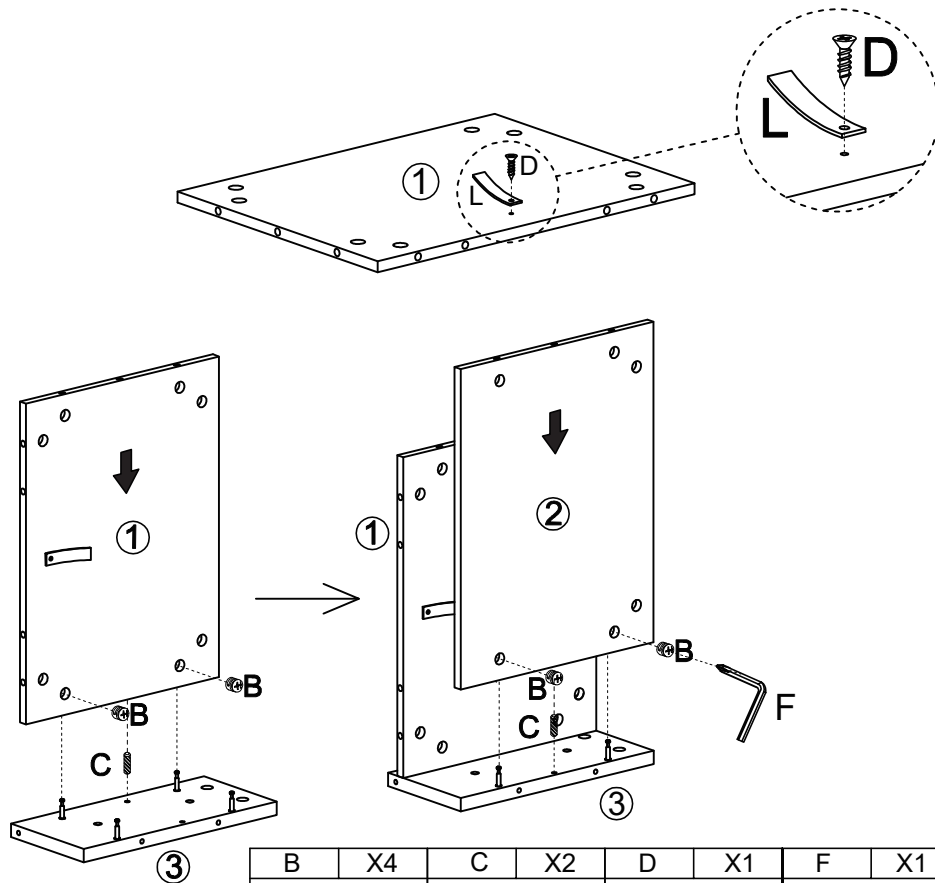

A	X20
	
φ6X35mm	



Step 02



B	X4	C	X2	D	X1	F	X1	L	X1
									
φ15X10mm		φ6X30mm		3.5X14mm		M4X45X45mm		60X16mm	

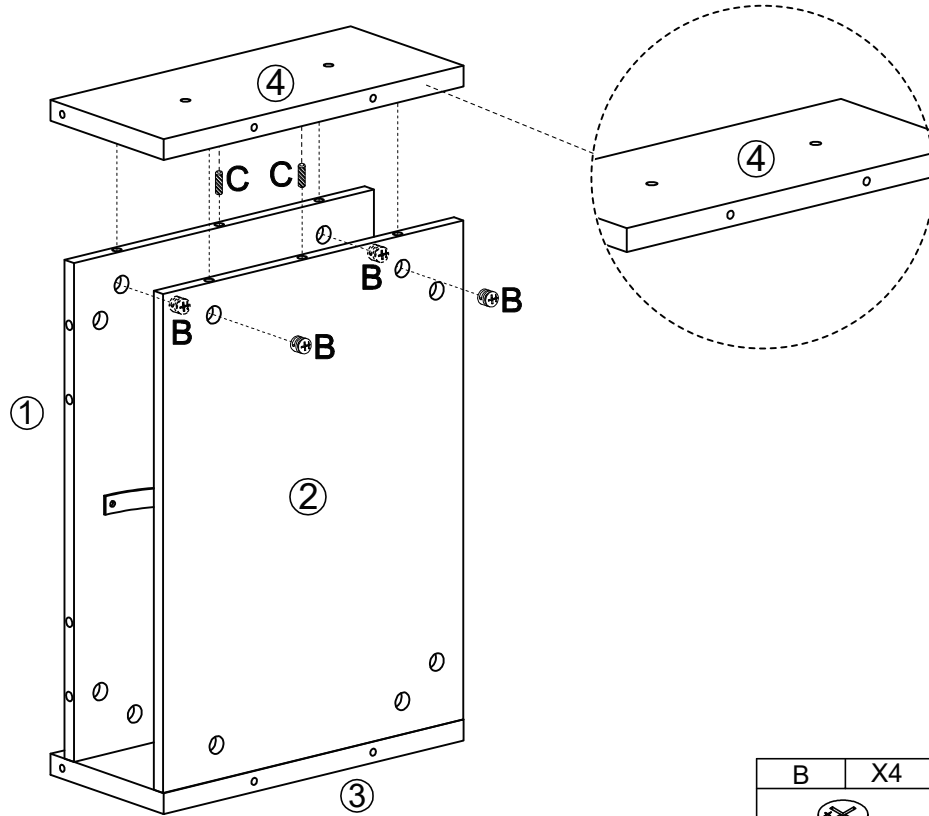

Step 03

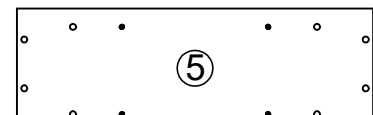
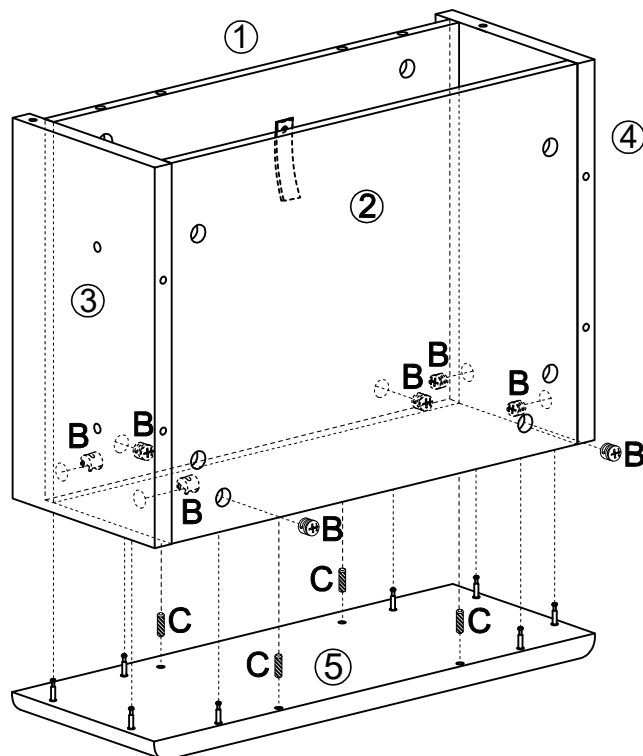

B	X4	C	X2
			
φ15X10mm		φ6X30mm	

Step 04





B	X8	C	X4
			
φ15X10mm		φ6X30mm	

Note the position of the holes in Board⑤, with the upper holes far from the edge and the lower holes close to the edge.

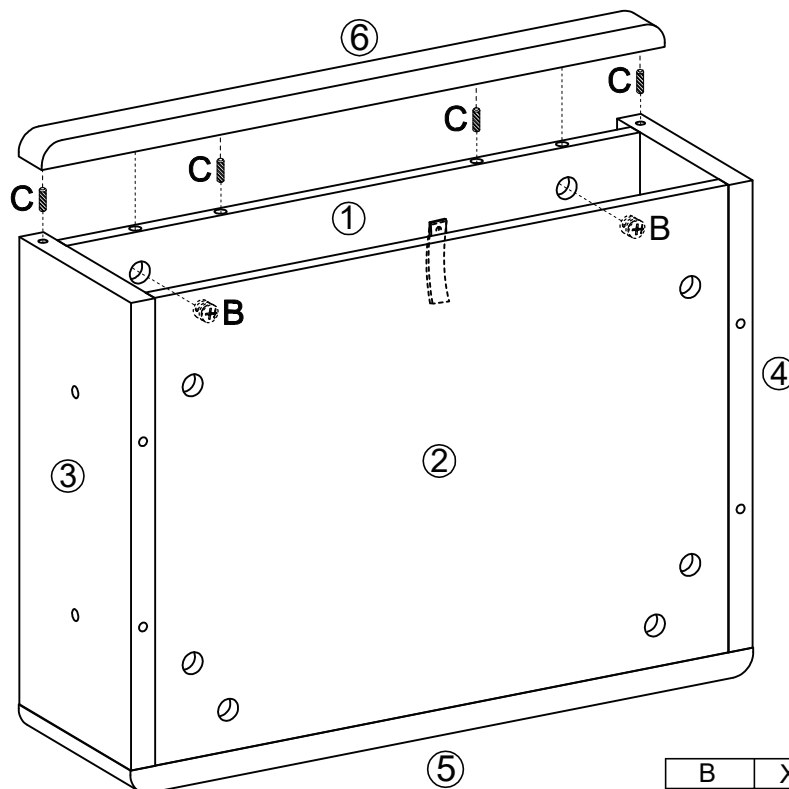

Step 05

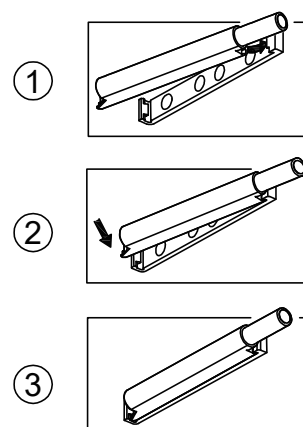
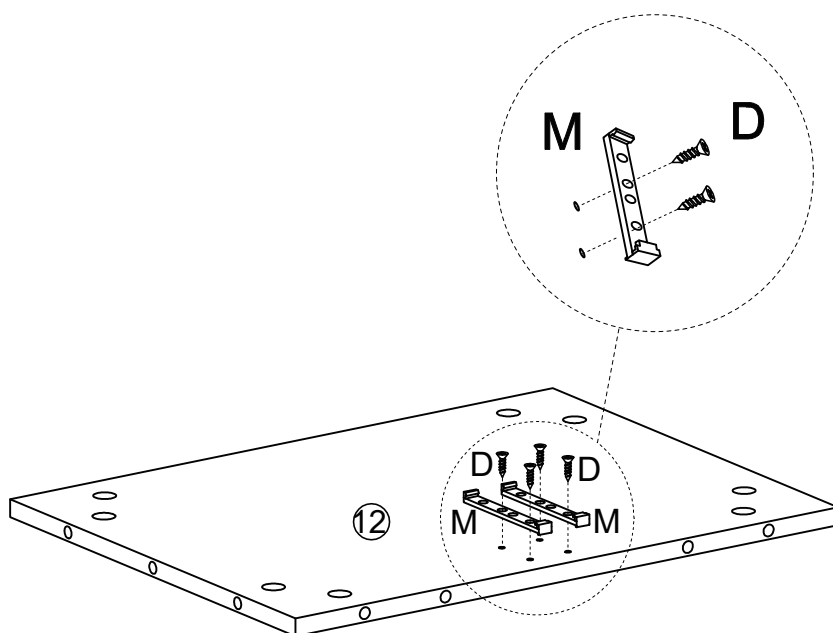

B	X2	C	X4
			
φ15X10mm		φ6X30mm	

Step 06



D	X4	M	X2
			
3.5X14mm			

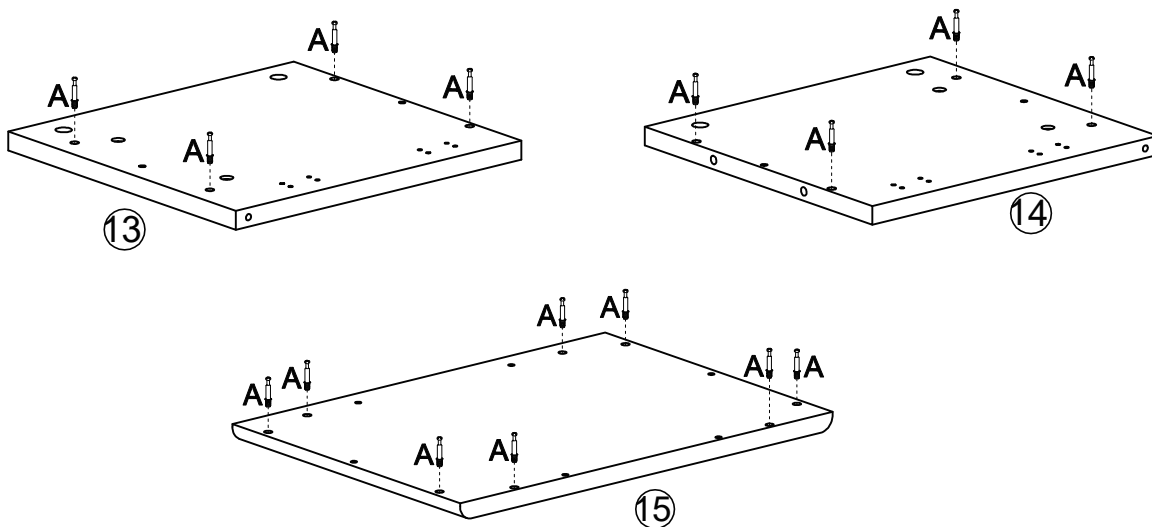

Step 07

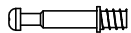

A	X16
	
φ6X35mm	

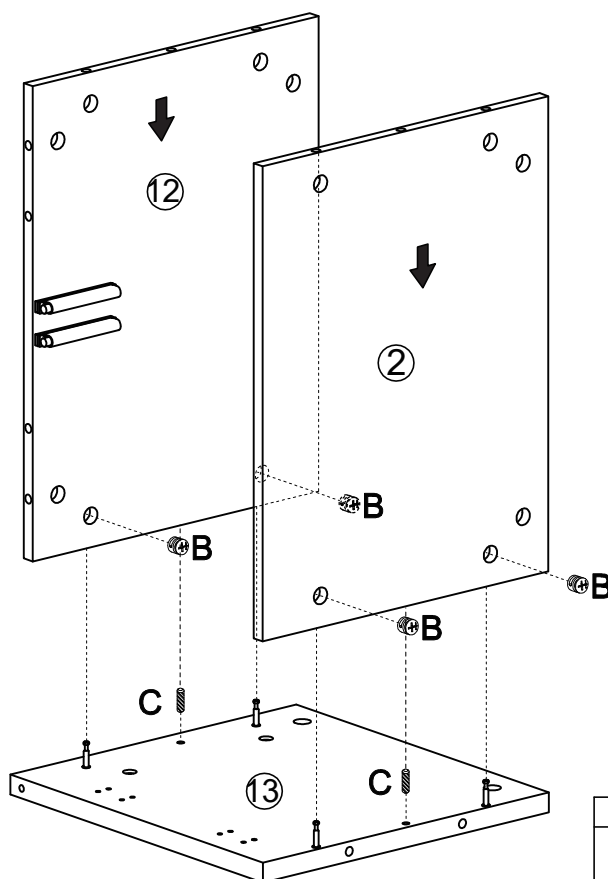
Step 08



B	X4	C	X2
			
φ15X10mm		φ6X30mm	

Step 09

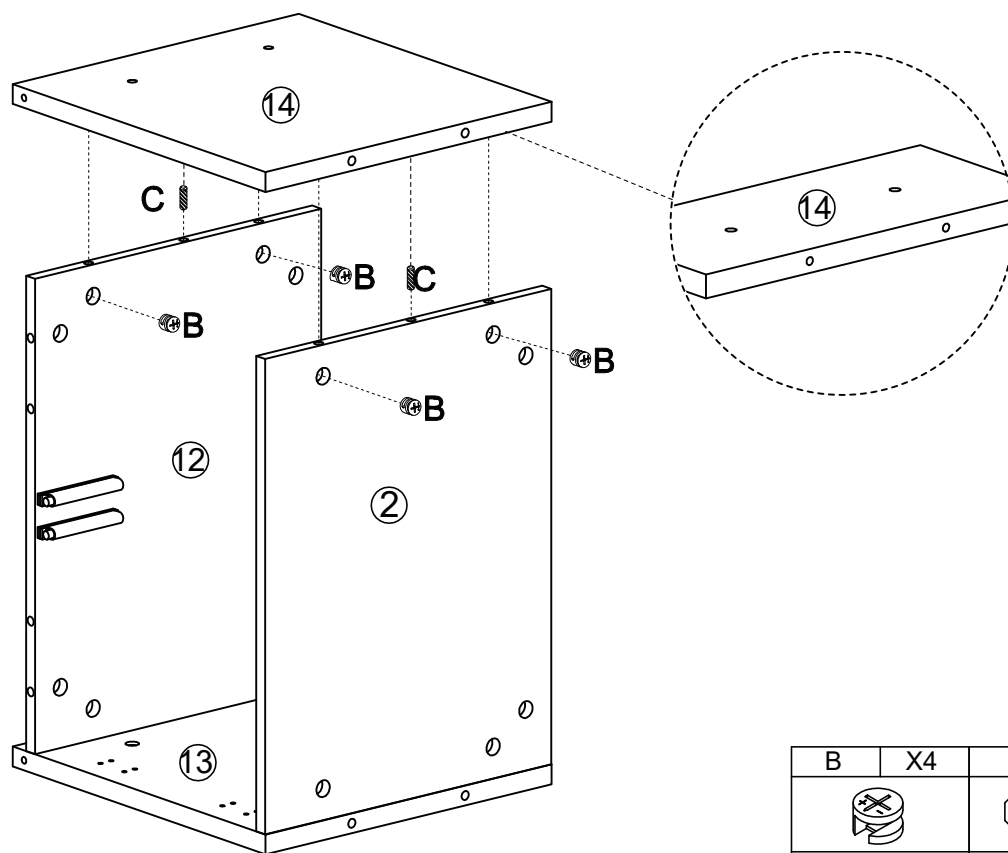

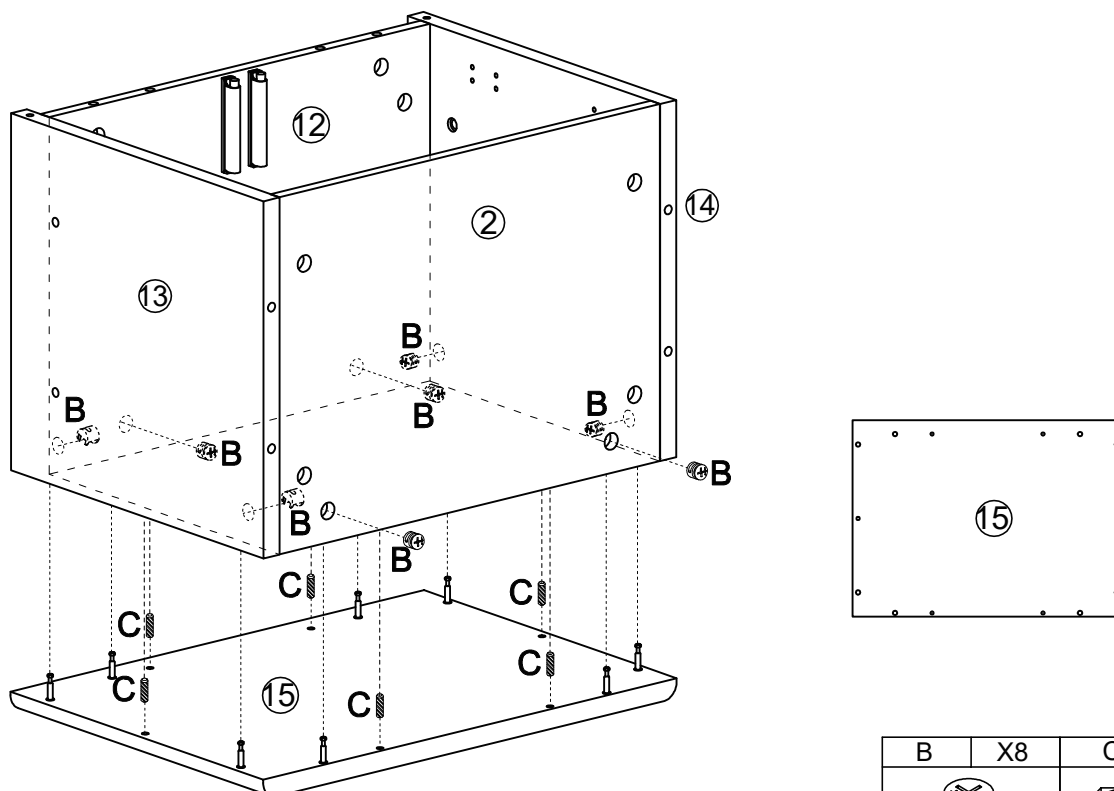

Step 10

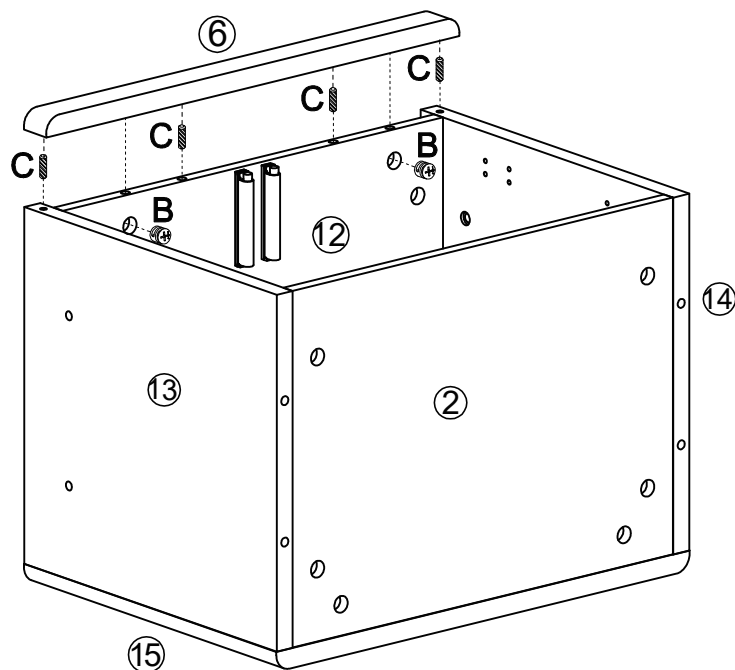

Note the position of the holes in Board (15), with the upper holes far from the edge and the lower holes close to the edge.

Step 11





B	X2	C	X4
			
φ15X10mm		φ6X30mm	

Step 12

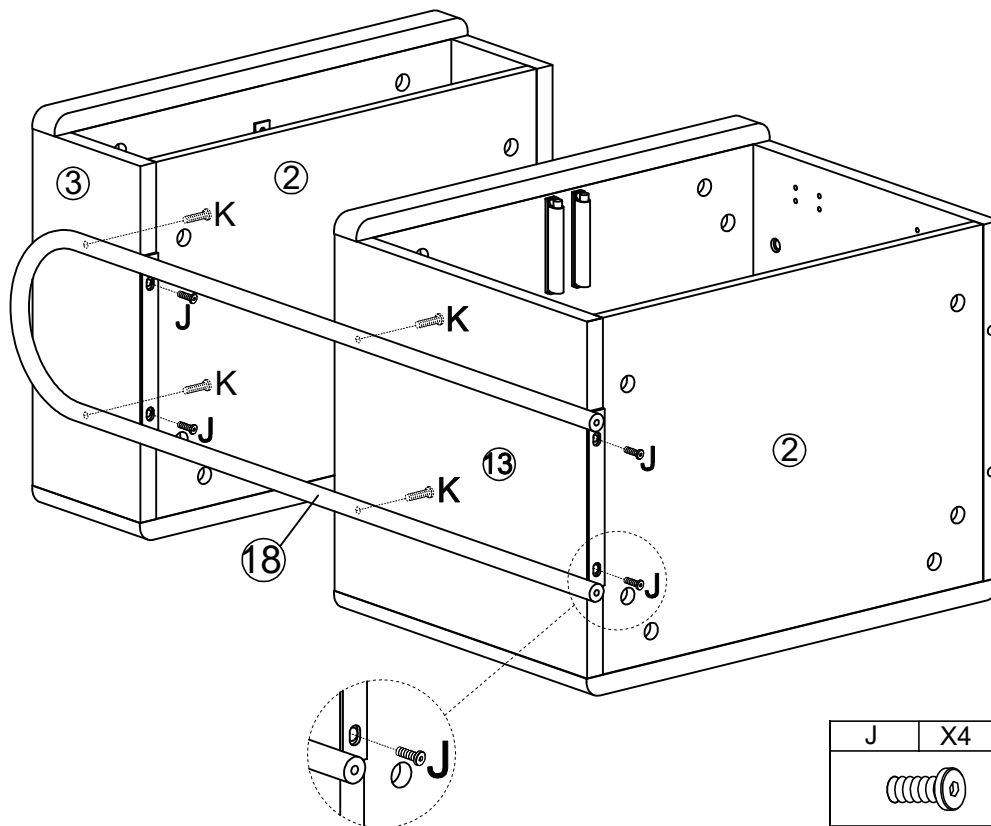
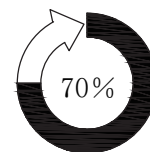
70%: Please do not tighten all screws firmly.



J	X4	K	X4
			
M6X12mm		M6X28mm	

Step 13

70%: Please do not tighten all screws firmly.

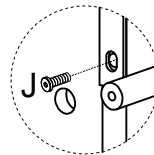
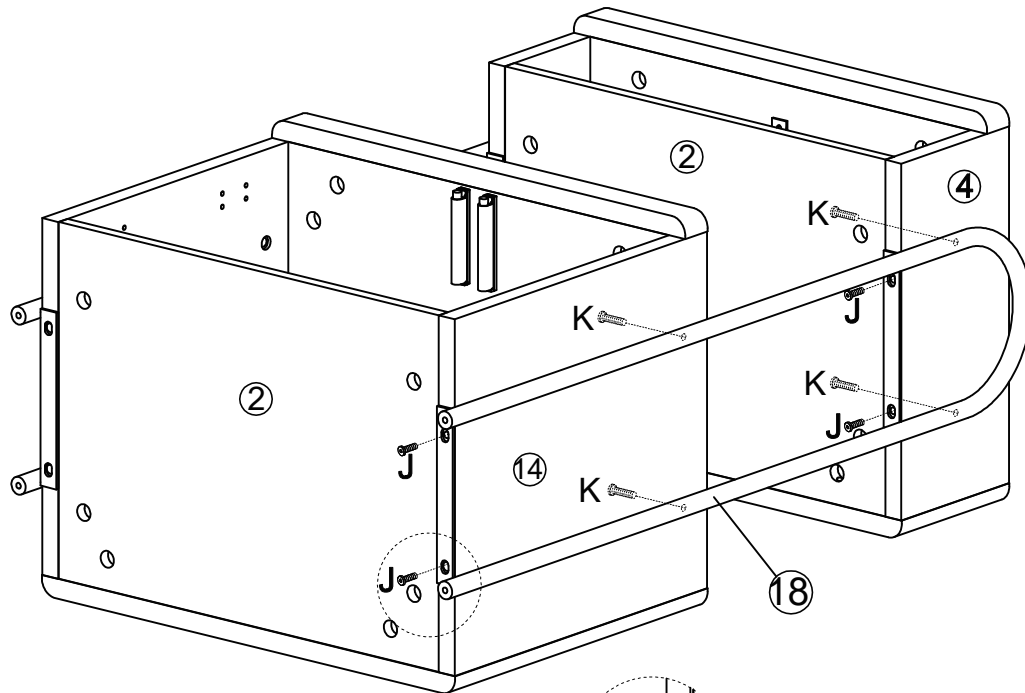

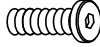
J	X4	K	X4
			
M6X12mm		M6X28mm	

Step 14

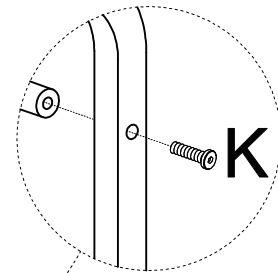
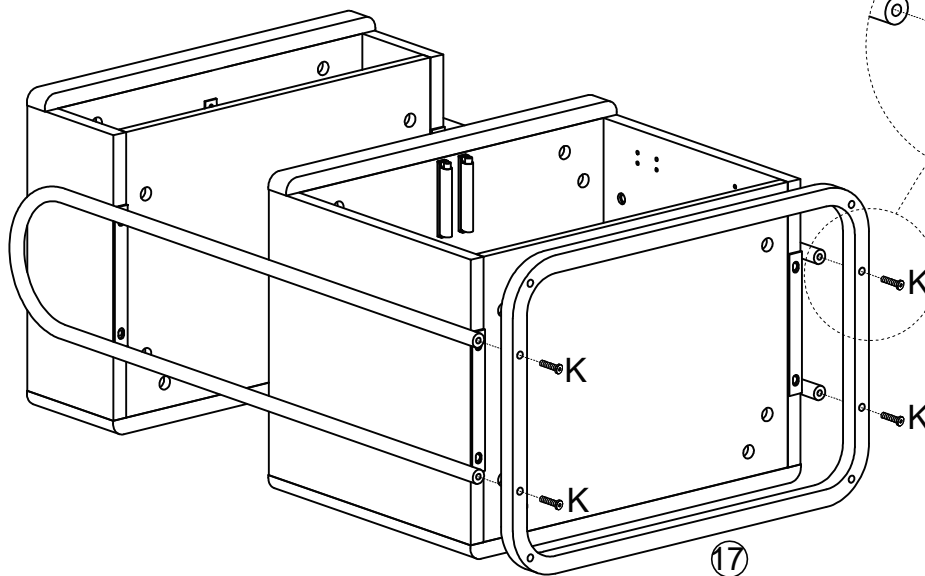

100%: Please tighten all screws firmly after finishing this step.

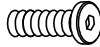

K	X4
	
M6X28mm	

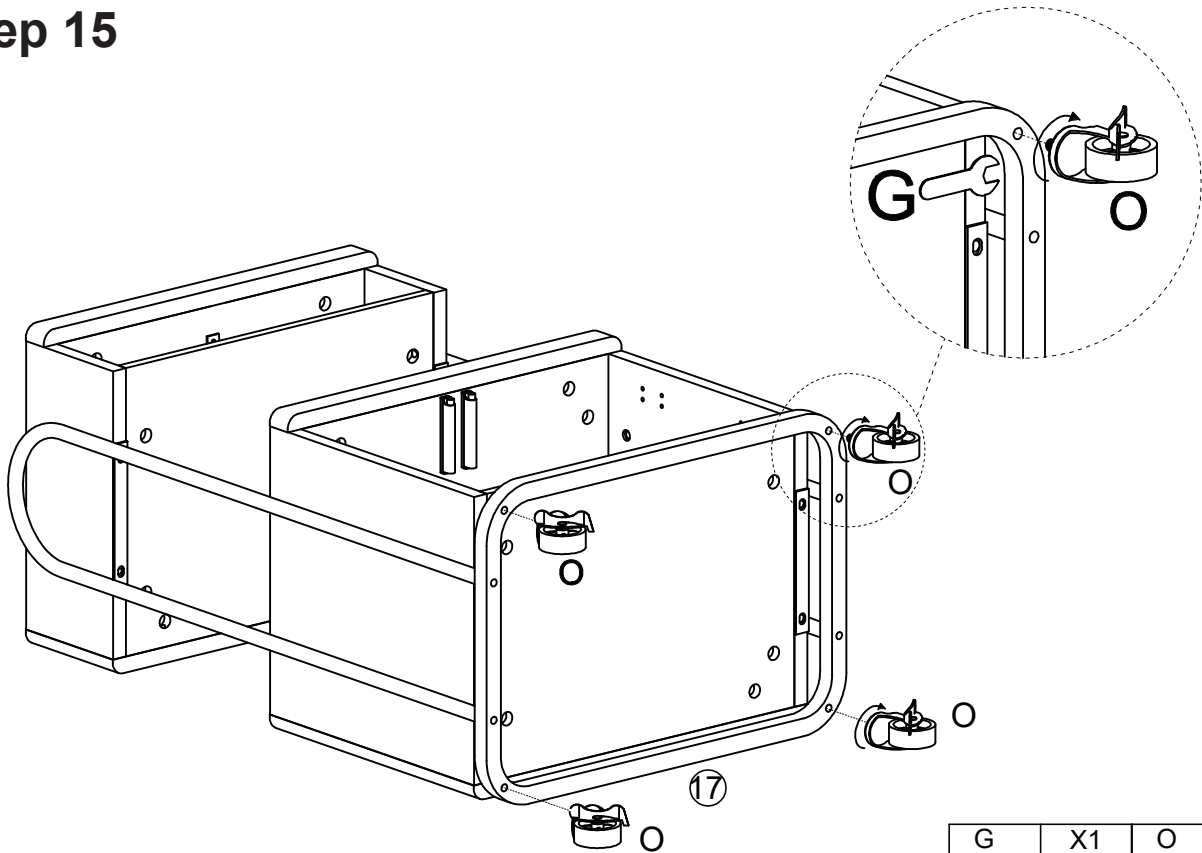



Step 15

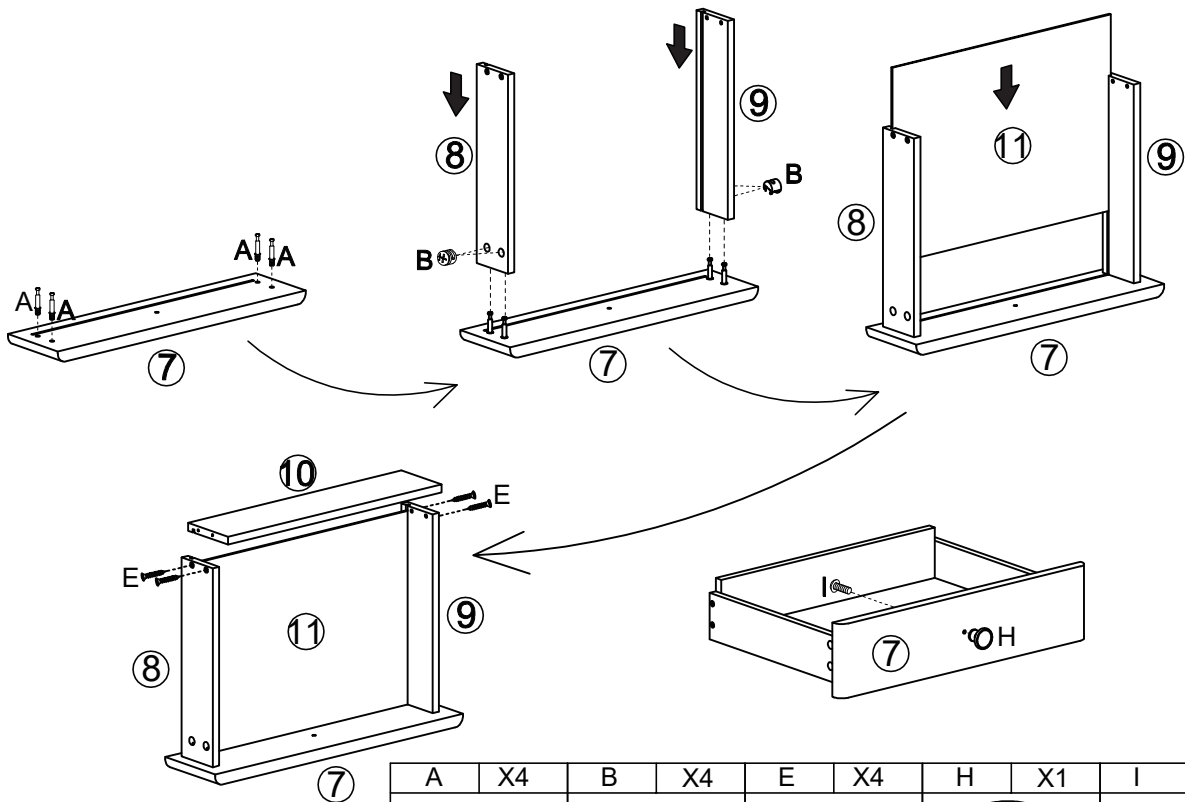

G	X1	O	X4
			
M8XØ50mm			

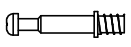
Step 16



A	X4	B	X4	E	X4	H	X1	I	X1
									
φ6X35mm		φ15X10mm		φ4X35mm		φ31X28mm		M4X22mm	

Step 17

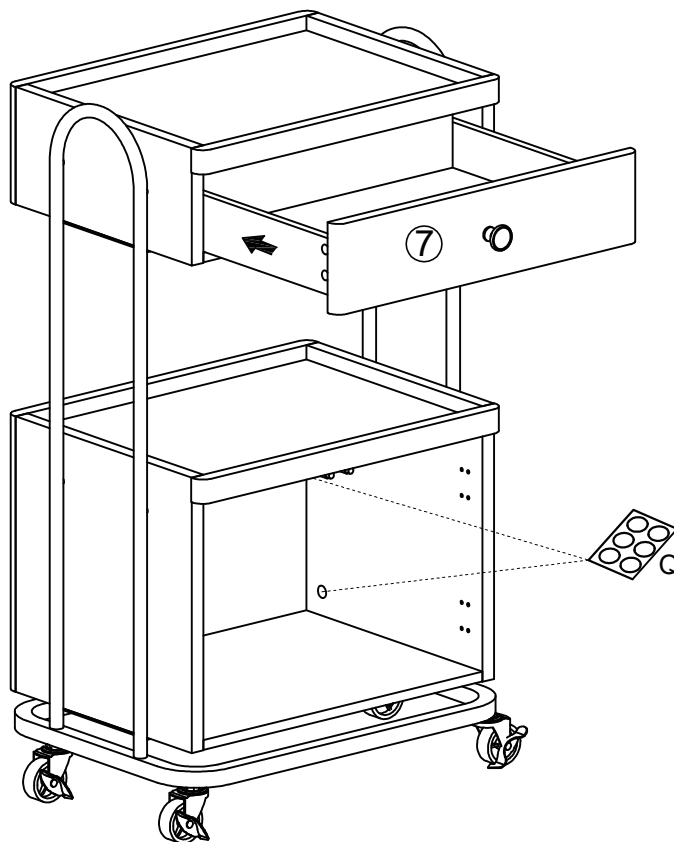

Q	X1
φ20	

Step 18

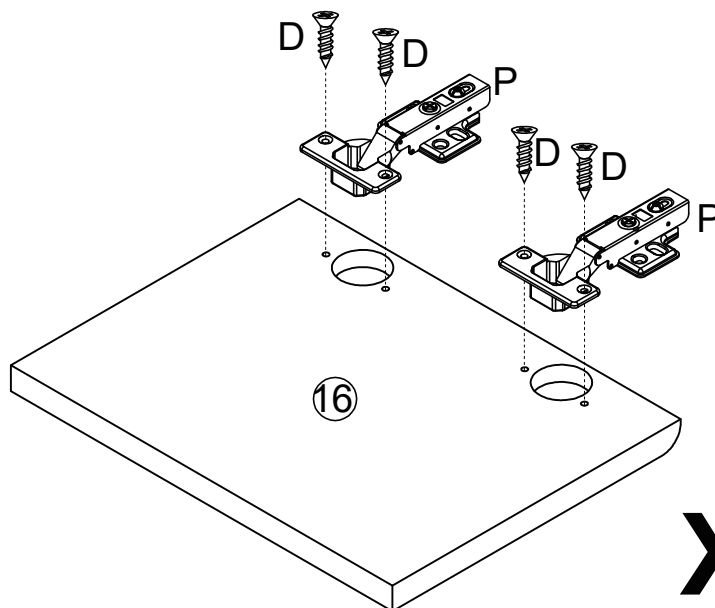

X2

D	X8	P	X4
3.5X14mm			

Step 19

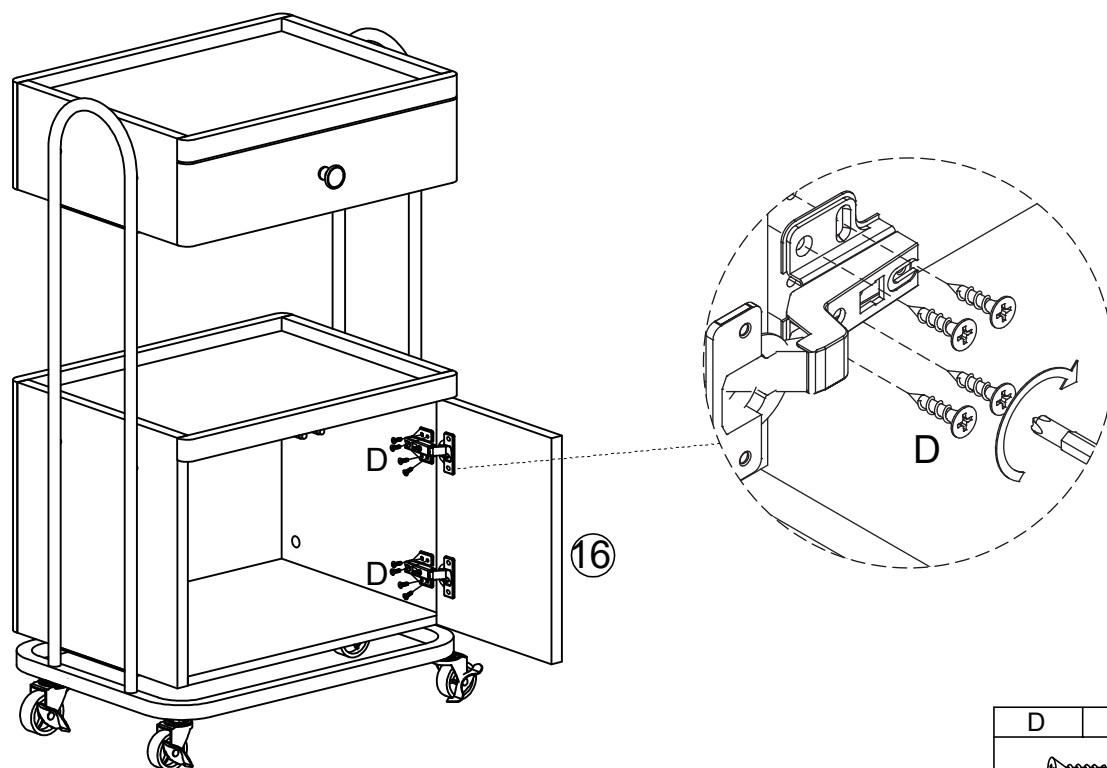

D	X8
	
3.5X14mm	

Step 20

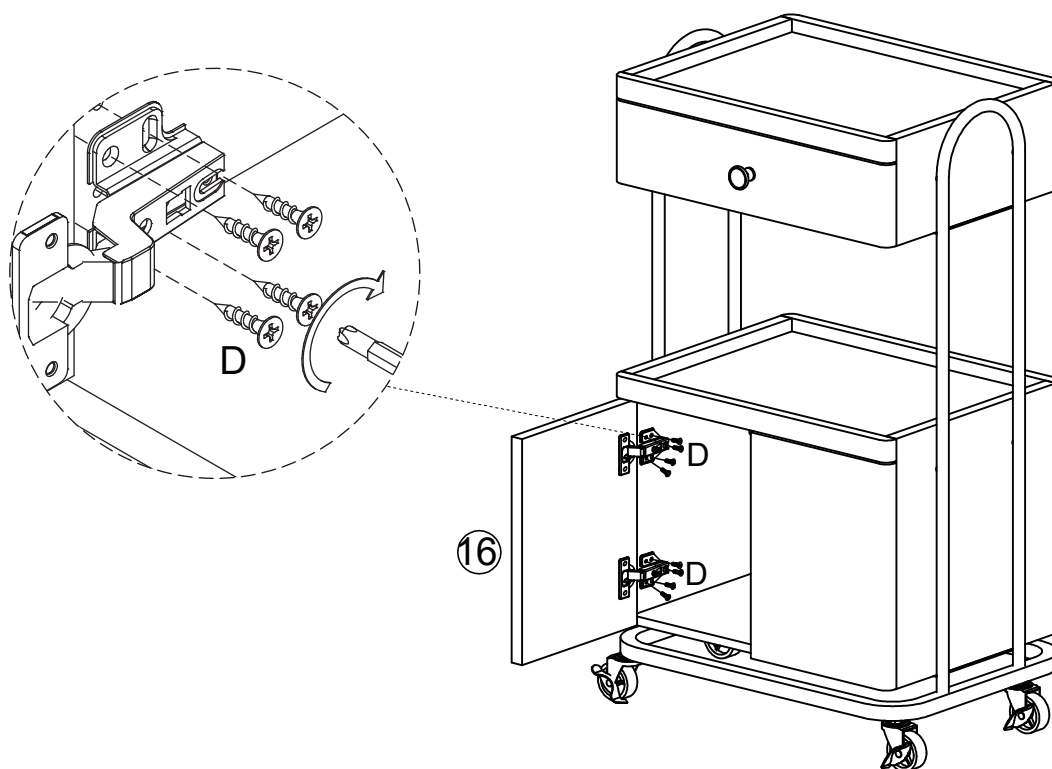

D	X8
	
3.5X14mm	



If the door sags, loosen screw A and adjust the height of the hinge up and down, then tighten screw A again when there is no problem.

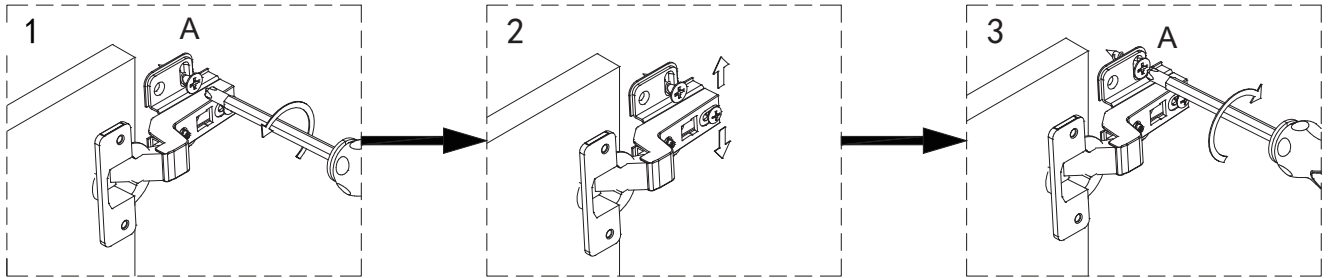

If the door does not close tightly, loosen screw B and adjust the hinge left and right, then tighten screw B again if there is no problem.

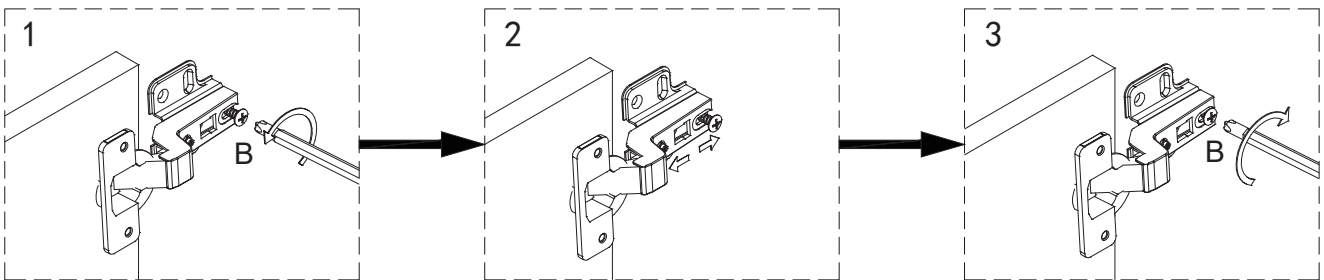

If the door gap is big, loosen screw B and turn the screw C, then adjust the hinge back and forth, after no problem tighten the screw B again.

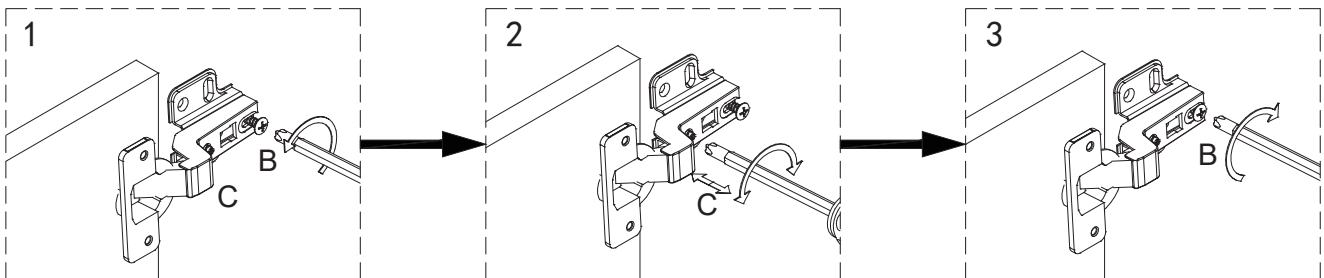

Step 21

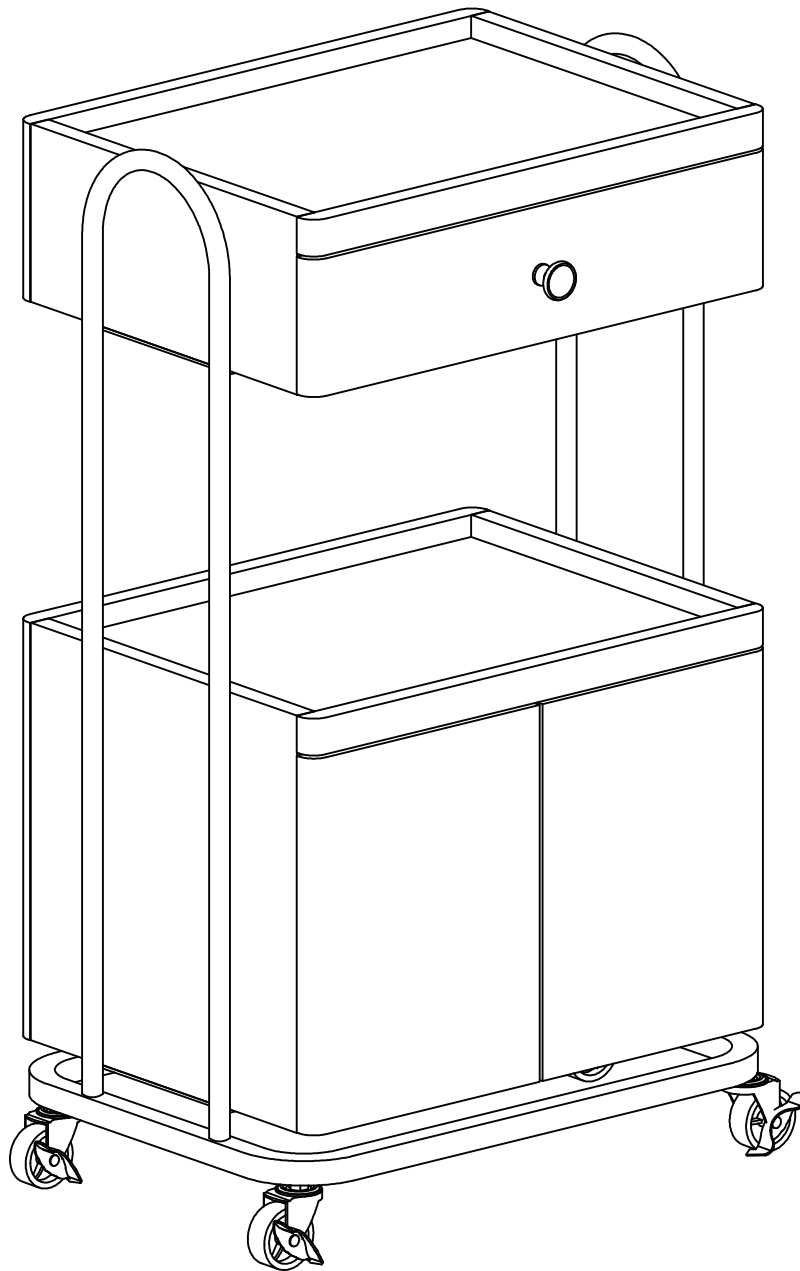

MCOMBO KUNDENDIENST

Ist das Produkt vollständig erhalten? Ist die Installation und Nutzung reibungslos verlaufen?

Wenn Sie Fragen oder Anregungen haben, setzen Sie sich bitte rechtzeitig mit uns in Verbindung. Wir werden unser Bestes versuchen, um das Problem zu lösen.

Haben Sie spezielle Anforderungen an Größe, Farbe, Stil, Material oder andere Aspekte Ihres Produkts?

Zögern Sie nicht, uns zu kontaktieren, wir verstehen Ihre Bedürfnisse gerne und bieten Ihnen bessere Produkte.

	0049-(0)21511561192
	pfillo.de@gmail.com (innerhalb 24h)
	Kreuzweg 60, 47809 Krefeld, Deutschland

MCombo®

MCombo®



Mcombo.de

Product Name: Service trolley
Model: 6090-0086
Production Batch: 08429381088353
Country Origin: Made in China
Manufacturer: Pfillo GmbH
Address: Brehmstraße 56,
40239 Düsseldorf, Germany
E-Mail: info.de@newacmelc.com
Tel: 004921511561192



Pfillo GmbH
Brehmstraße 56, 40239 Düsseldorf, Germany
info.de@newacmelc.com
004921511561192



<https://www.pfillo.com/fr>