



BEDIENUNGSANLEITUNG
SERVICEWAGEN

SICHERHEITSHINWEISE



Lesen und befolgen Sie die Informationen im Benutzerhandbuch.



Bitte halten Sie Kinder aus Sicherheitsgründen von kleinen Komponenten fern.



Das Produkt soll in einer trockenen Umgebung verwendet werden.



Bitte beachten Sie, dass Holz nicht kratzfest ist.



Wasserflecken und Flecken soll rechtzeitig gereinigt werden.



Platzieren Sie keine übergewichtigen Gegenstände.



Bitte behandeln Sie Holz und anderes Zubehör sachgemäß.

— HAFTUNGSAUSSCHLUSS —

Wir bitten Sie, diese Anleitung vollständig zu lesen, bevor Sie den Artikel zusammenbauen und in Betrieb nehmen. Wir sind nicht und können nicht für Schäden oder Verletzungen verantwortlich gemacht werden, die durch unsachgemäße oder unsichere Verwendung des Artikels entstehen. Wir lehnen ausdrücklich die Verantwortung für Körperverletzungen oder Sachschäden ab, die bei einer Verwendung auftreten können, die nicht den geltenden Bundes-, Landes- oder lokalen Gesetzen oder Verordnungen entspricht. Bitte bewahren Sie dieses Handbuch für zukünftige Bezugnahme auf.

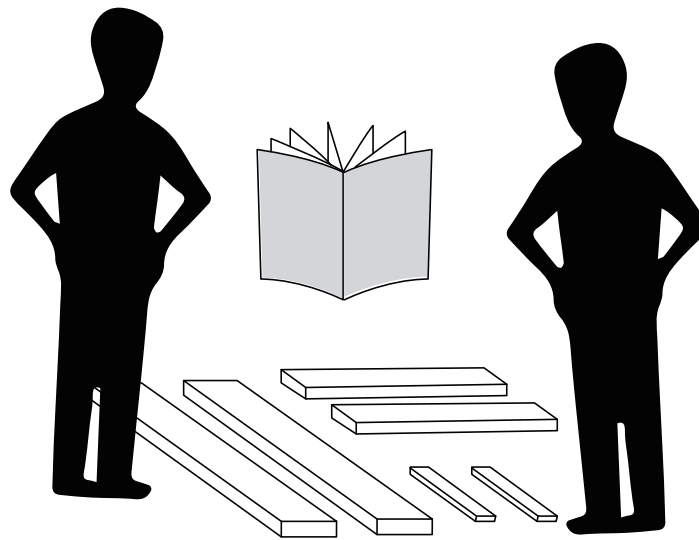

INSTALLATIONSVORBEREITUNG



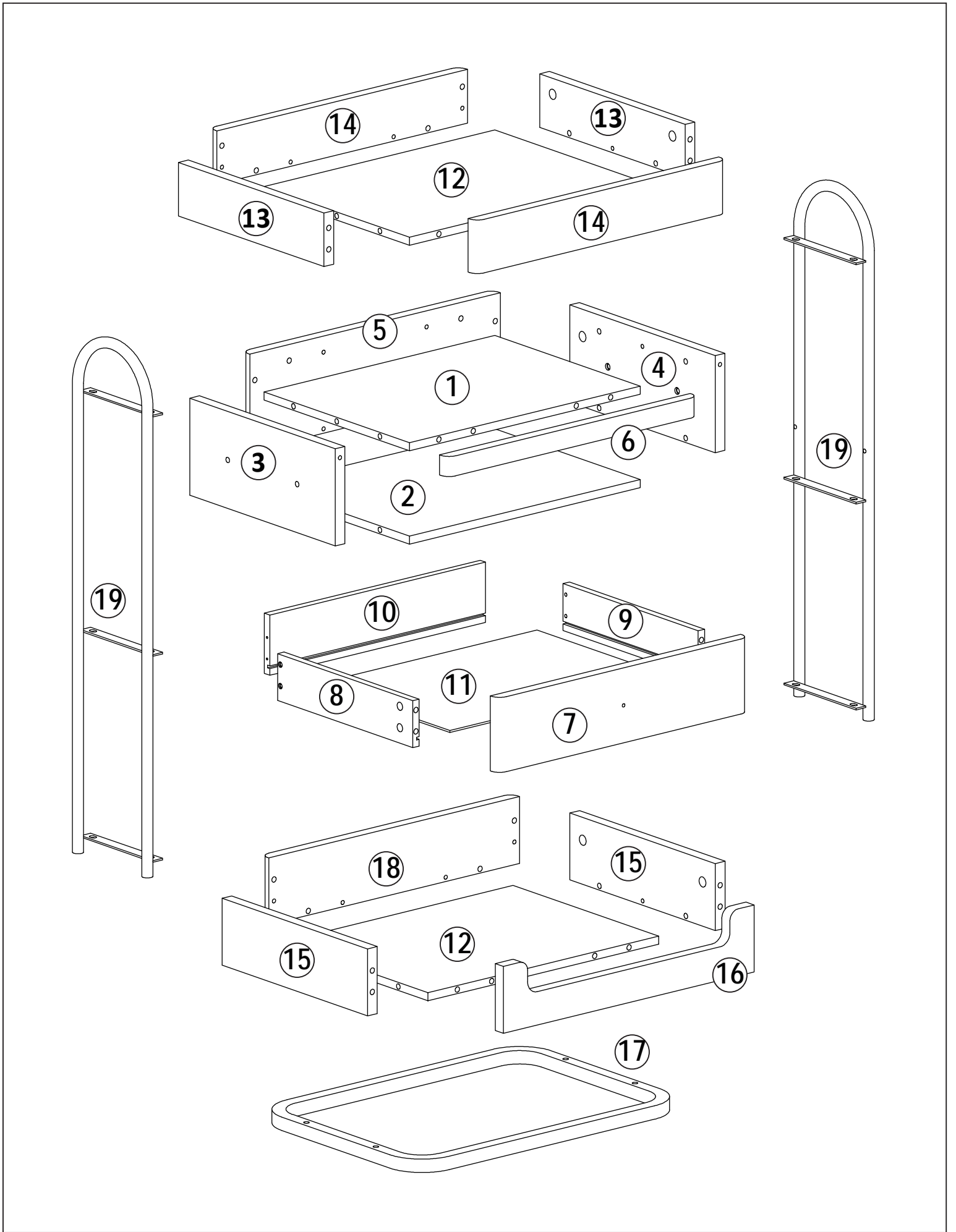



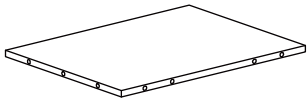
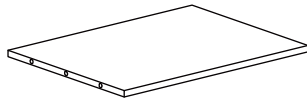
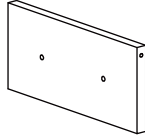
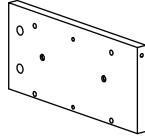
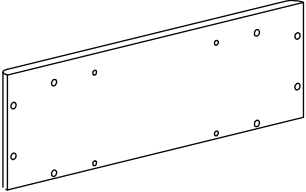
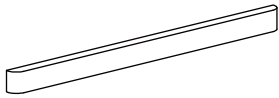
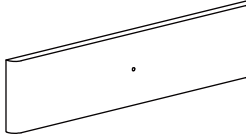
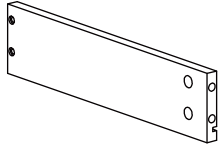
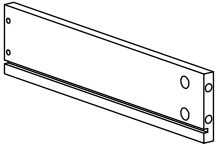
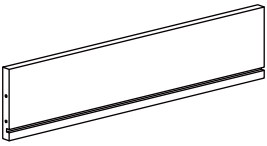
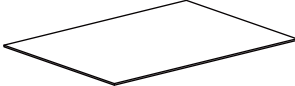
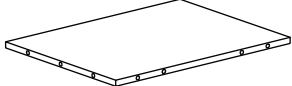
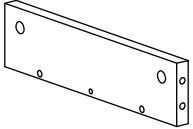
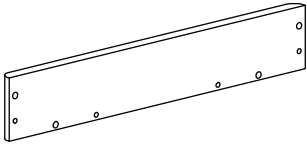
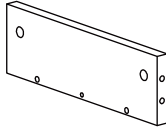
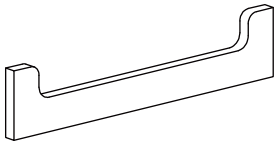
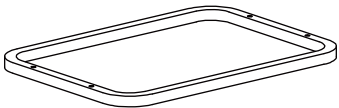
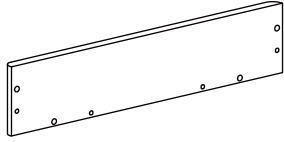

- Bitte bereiten Sie einen Teppich oder eine Matte vor, um Ihren Boden zu schützen. Sie müssen alle Zubehörteile auslegen.
- Bitte bereiten Sie ein Paar Handschuhe vor, um Kratzer durch scharfes Holzsägemehl zu vermeiden, das während der Installation auftreten kann.
- Bitte öffnen Sie alle Kartons, um zu überprüfen, ob das Zubehör vollständig und in gutem Zustand ist.
- Die Box enthält einige kleine Komponenten, bitte platzieren Sie sie vor der Installation richtig, um sie von Kindern fernzuhalten und die Sicherheit zu gewährleisten.
- Wenn Sie Elektrowerkzeuge verwenden müssen, um dieses Produkt zu installieren, stellen Sie bitte die Geschwindigkeit im Voraus auf niedrige Geschwindigkeit ein.
- Richten Sie bei der Installation bitte alle Löcher aus, bevor Sie alle Schrauben festziehen.

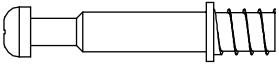

ZUBEHÖRTEILE

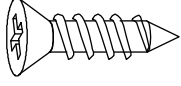
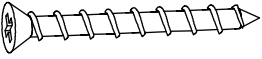
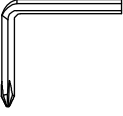
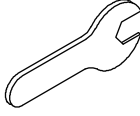
<p>①</p>  <p>430*323mm x1</p>	<p>②</p>  <p>430*323mm x1</p>	<p>③</p>  <p>323*145mm x1</p>	<p>④</p>  <p>323*145mm x1</p>
<p>⑤</p>  <p>467*145mm x1</p>	<p>⑥</p>  <p>467*30mm x1</p>	<p>⑦</p>  <p>467*112mm x1</p>	<p>⑧</p>  <p>300*70mm x1</p>
<p>⑨</p>  <p>300*70mm x1</p>	<p>⑩</p>  <p>402*90mm x1</p>	<p>⑪</p>  <p>411*296mm x1</p>	<p>⑫</p>  <p>430*323mm x2</p>
<p>⑬</p>  <p>323*80mm x2</p>	<p>⑭</p>  <p>467*80mm x2</p>	<p>⑮</p>  <p>323*100mm x2</p>	<p>⑯</p>  <p>467*100mm x1</p>
<p>⑰</p>  <p>503*360mm x1</p>	<p>⑱</p>  <p>467*100mm x1</p>	<p>⑲</p>  <p>785*170mm x2</p>	

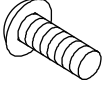
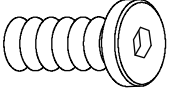
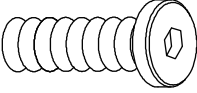
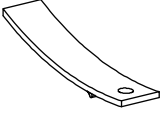
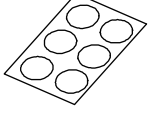
SCHRAUBENGRUPPE

<p>(A)</p>  <p>$\text{\O}6*35\text{mm}$ x46</p>	<p>(B)</p>  <p>$\text{\O}15*10\text{mm}$ x46</p>	<p>(C)</p>  <p>$\text{\O}6*30\text{mm}$ x32</p>	<p>(D)</p>  <p>$\text{\O}3.5*14\text{mm}$ x1</p>
<p>(E)</p>  <p>$\text{\O}4*35\text{mm}$ x4</p>	<p>(F)</p>  <p>$\text{M}4*45\text{mm}$ x1</p>	<p>(G)</p>  <p>x1</p>	<p>(H)</p>  <p>$\text{\O}31*28\text{mm}$ x1</p>
<p>(I)</p>  <p>$\text{M}4*22\text{mm}$ x1</p>	<p>(J)</p>  <p>$\text{M}6*12\text{mm}$ x12</p>	<p>(K)</p>  <p>$\text{M}6*28\text{mm}$ x8</p>	<p>(L)</p>  <p>$60*16\text{mm}$ x1</p>
<p>(M)</p>  <p>$\text{\O}20\text{mm}$ x2</p>	<p>(O)</p>  <p>$\text{M}8*\text{\O}50\text{mm}$ x4</p>		

INSTALLATIONSANLEITUNG

Schritt 1

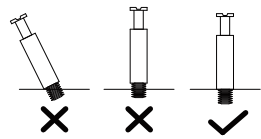

! #A müssen vollständig verschraubt werden.

- ③ X 1
- ④ X 1
- ⑤ X 1
- ⑥ X 1
- Ⓐ X 18

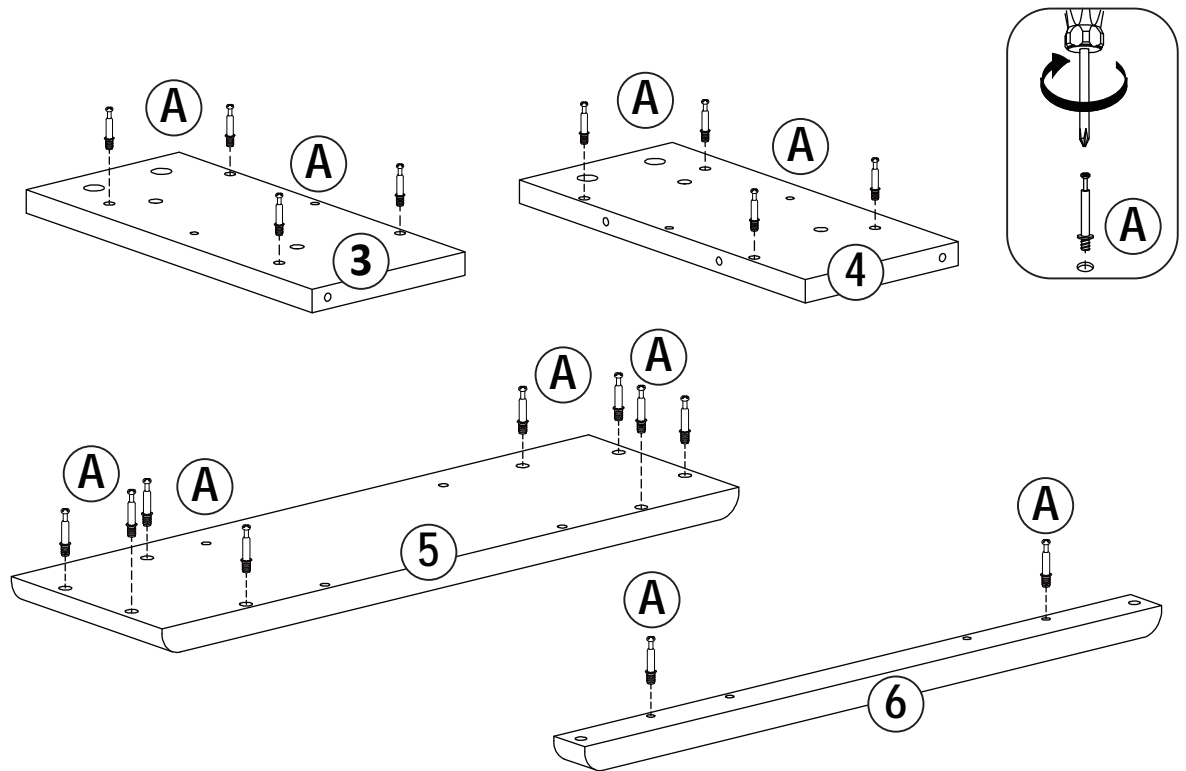

Schritt 2

- ① X 1
- ② X 1
- ③ X 1
- Ⓑ X 4
- Ⓒ X 2
- Ⓓ X 1
- Ⓕ X 1
- Ⓖ X 1
- Ⓛ X 1

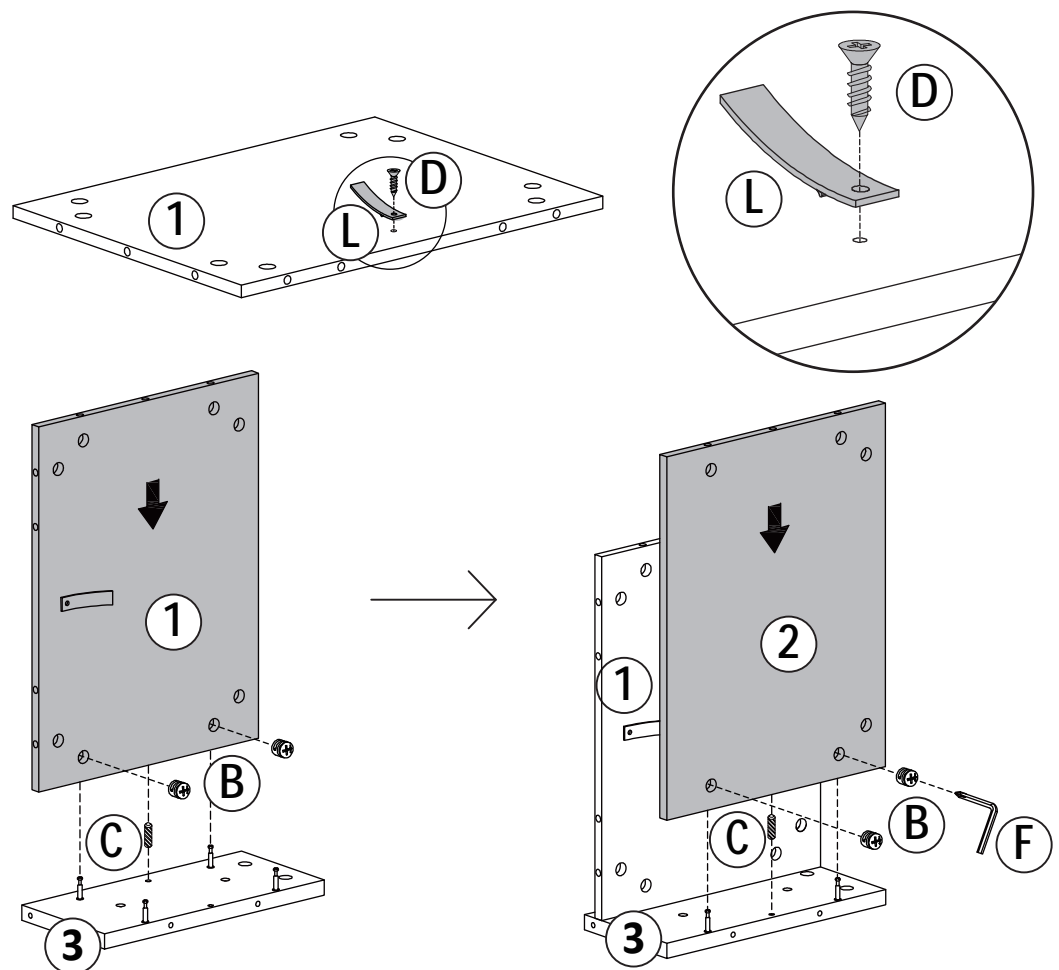

INSTALLATIONSANLEITUNG

Schritt 3

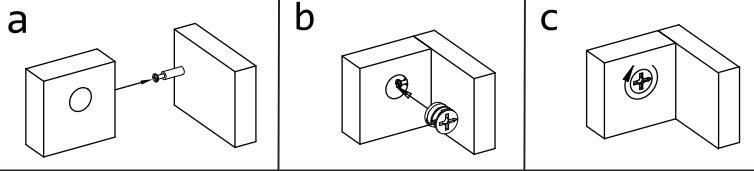

- ④ X 1
- Ⓑ X 4
- Ⓒ X 2

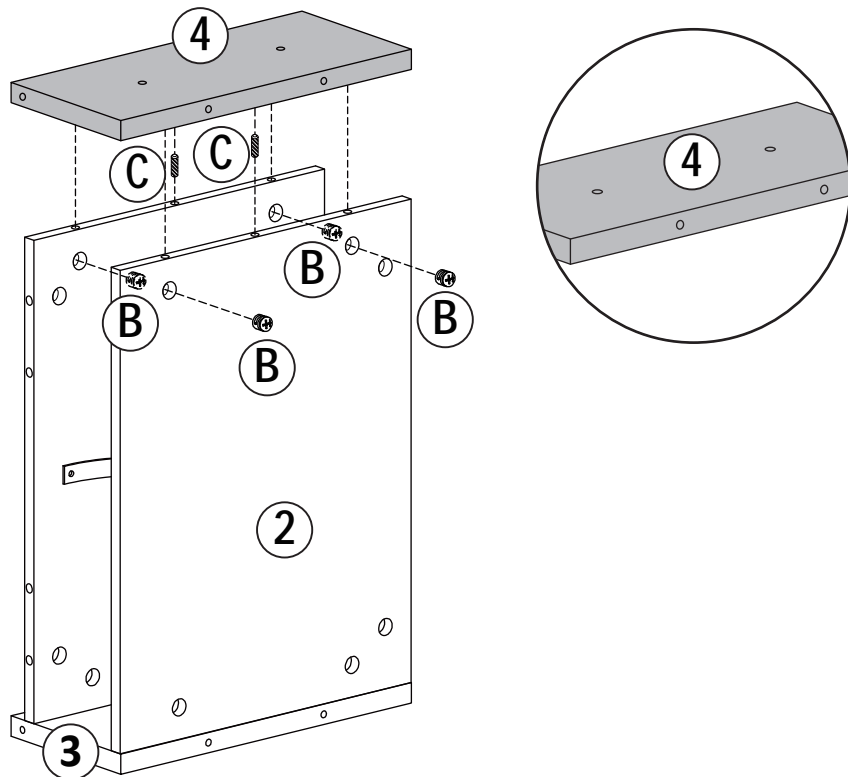

Schritt 4

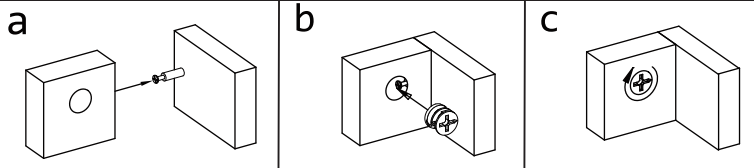

- ⑤ X 1
- Ⓑ X 8
- Ⓒ X 4

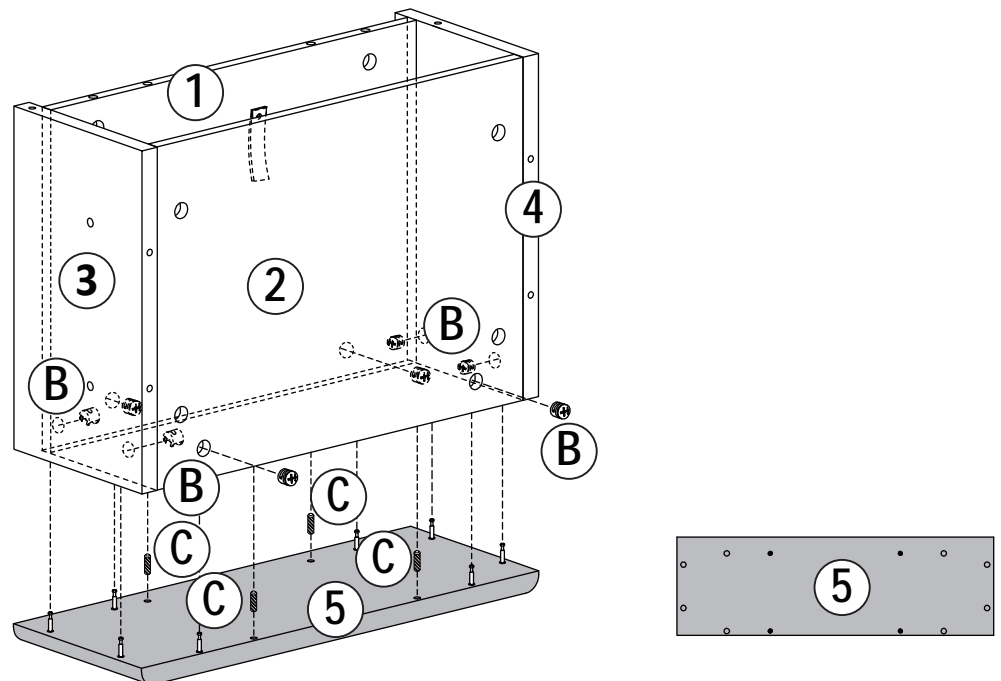

Beachten Sie die Position der Löcher in Brett ⑤, wobei die oberen Löcher weit vom Rand entfernt und die unteren Löcher nahe am Rand sind.

INSTALLATIONSANLEITUNG

Schritt 5

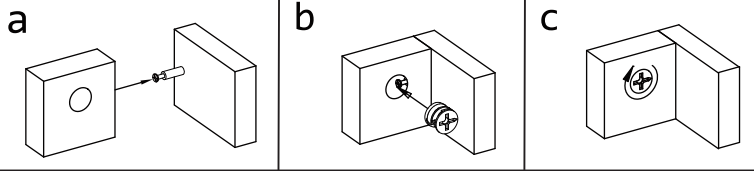

- ⑥ X 1
- ⑧ X 2
- ⑨ X 4

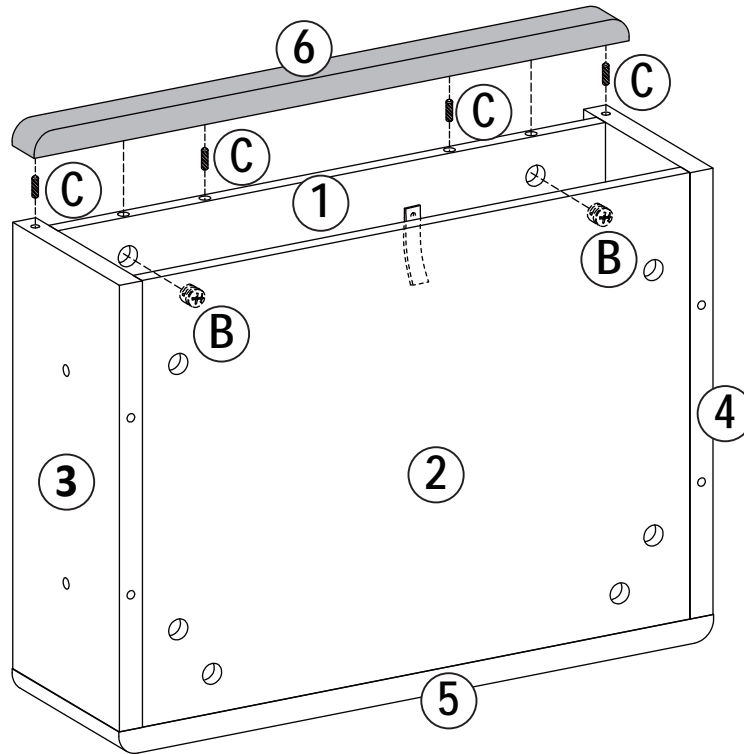

Schritt 6

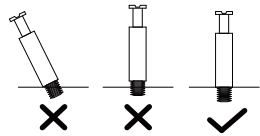

#A müssen vollständig verschraubt werden.

- ⑬ X 2
- ⑭ X 2
- ⑮ X 2
- ⑯ X 1
- ⑰ X 1
- Ⓐ X 24

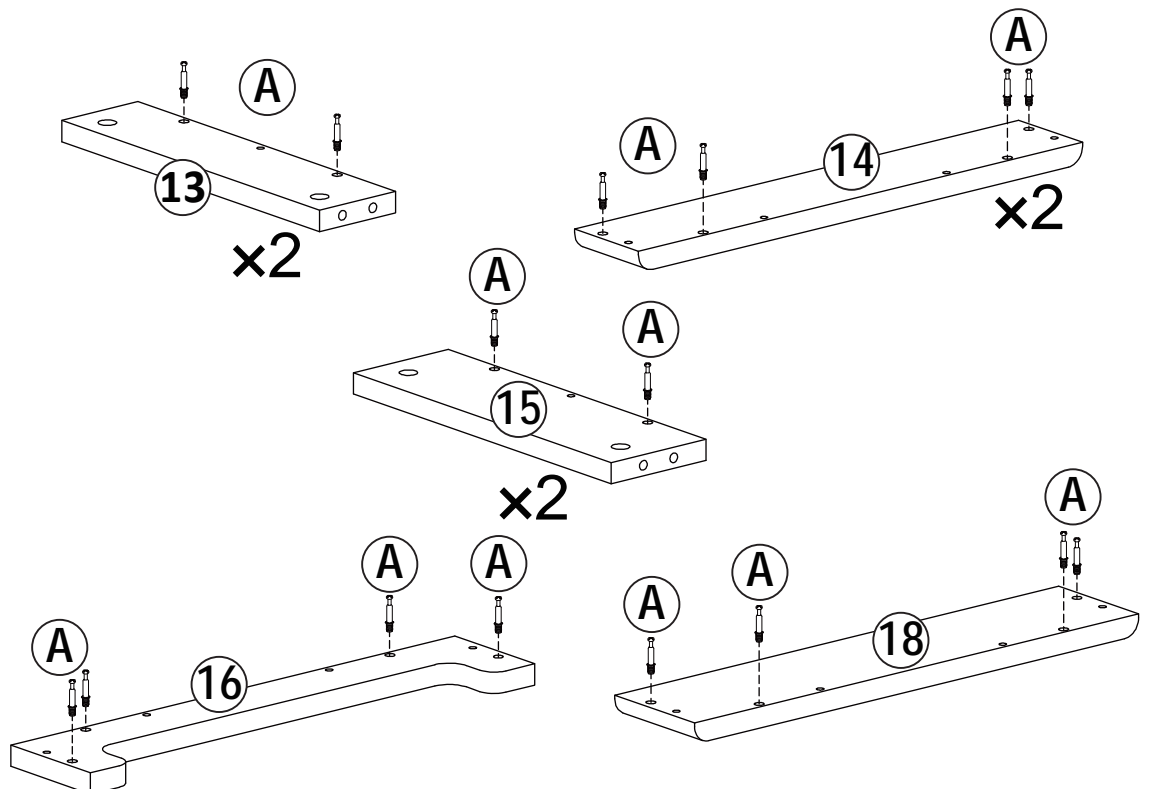

INSTALLATIONSANLEITUNG

Schritt 7

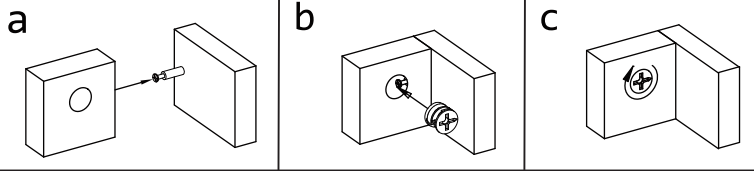

- ⓫ X 1
- ⓬ X 2
- ⓑ X 4
- ⓒ X 2

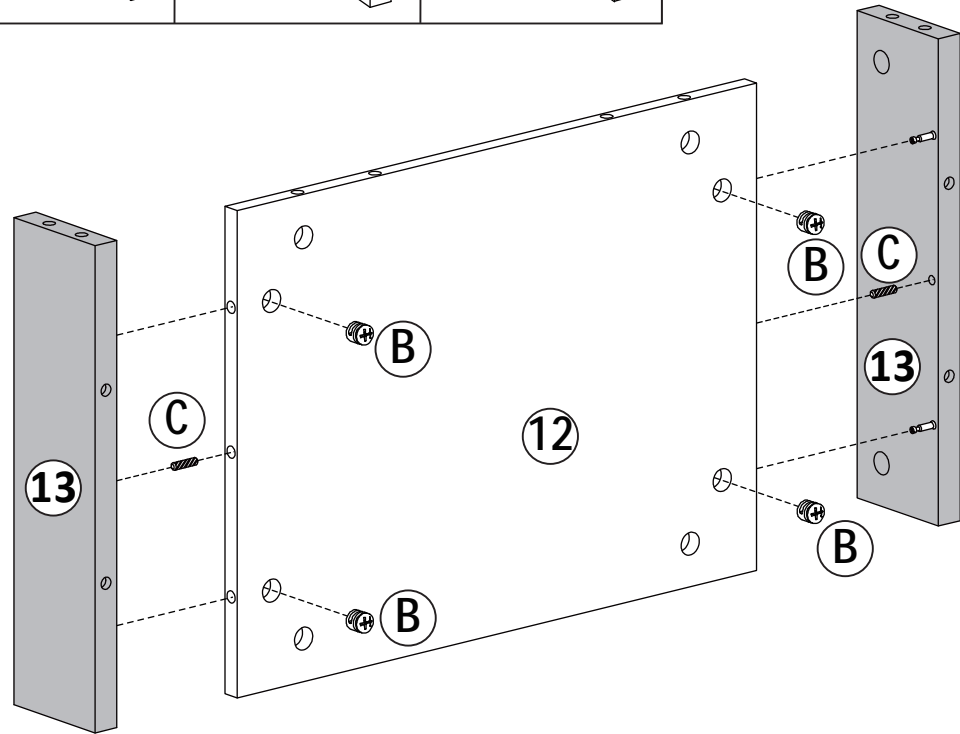

Schritt 8

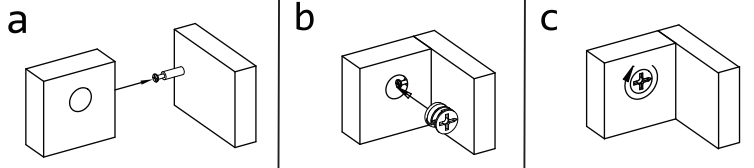

- ⓫ X 1
- ⓑ X 2
- ⓒ X 4

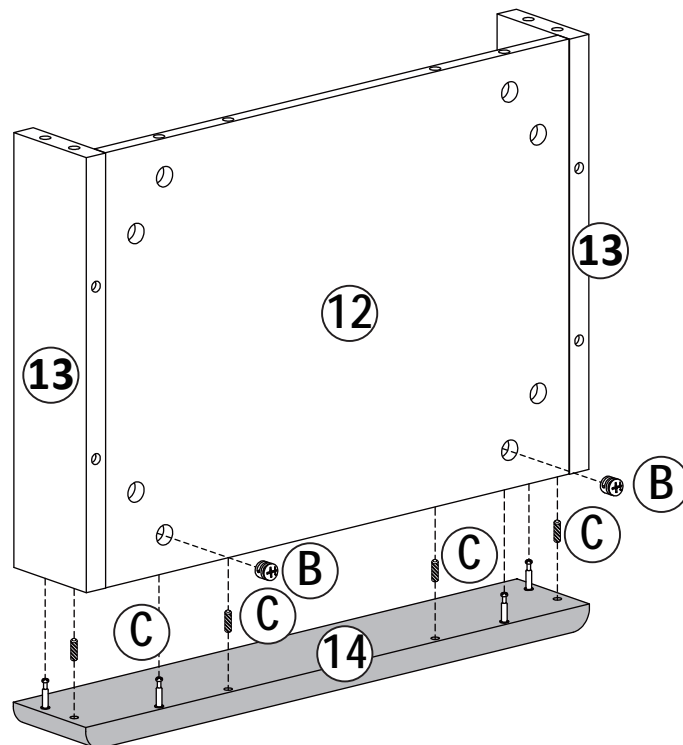

INSTALLATIONSANLEITUNG

Schritt 9

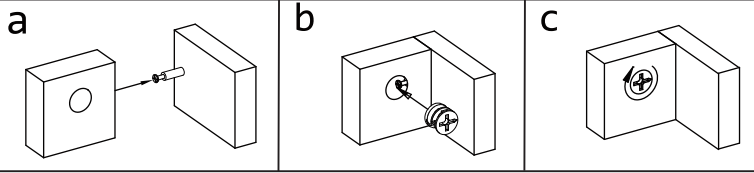

- ⑭ X 1
- Ⓑ X 2
- Ⓒ X 4

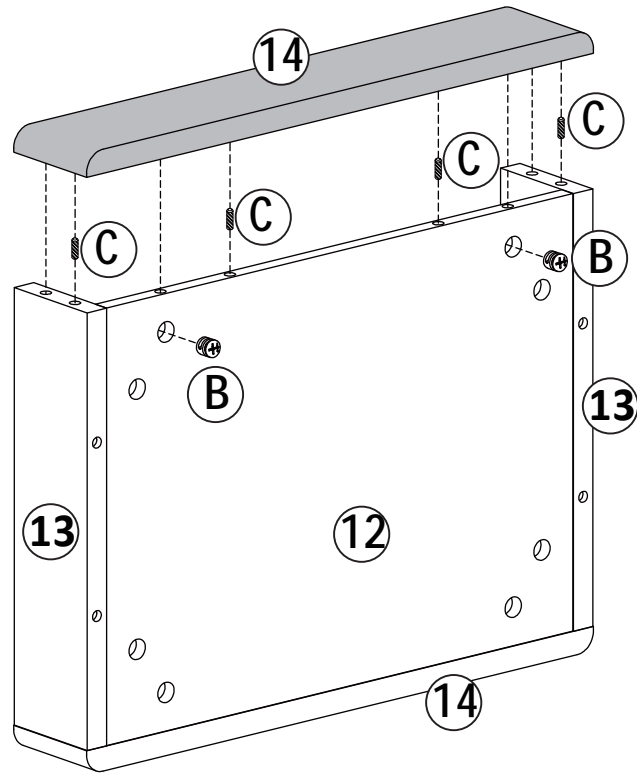

Schritt 10

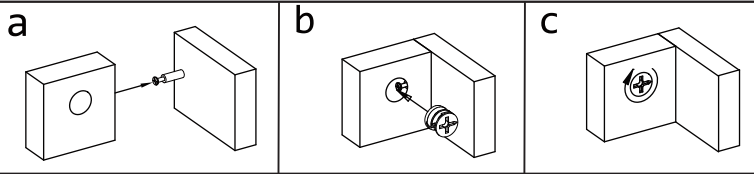

- Ⓑ X 4

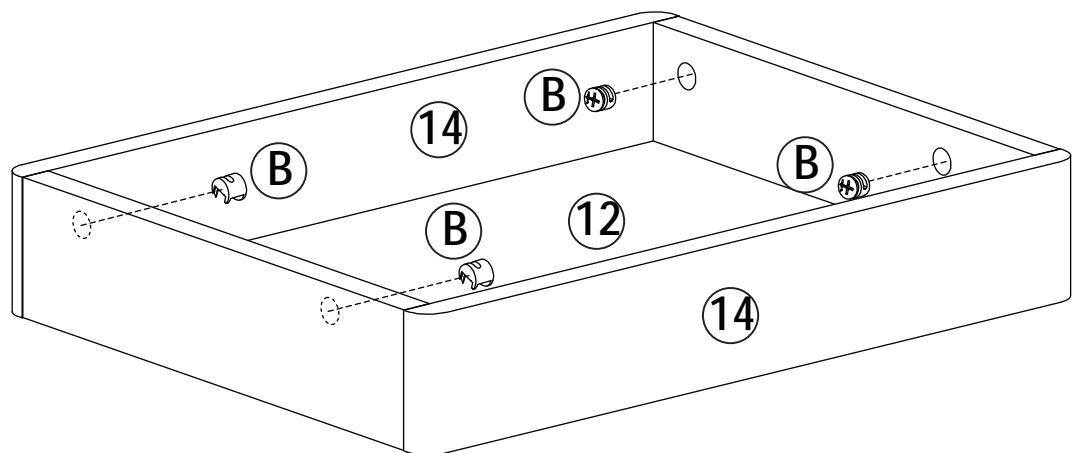

INSTALLATIONSANLEITUNG

Schritt 11

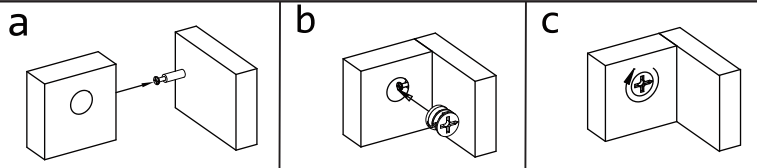

- ⓫ X 1
- ⓭ X 2
- ⓑ X 4
- ⓒ X 2

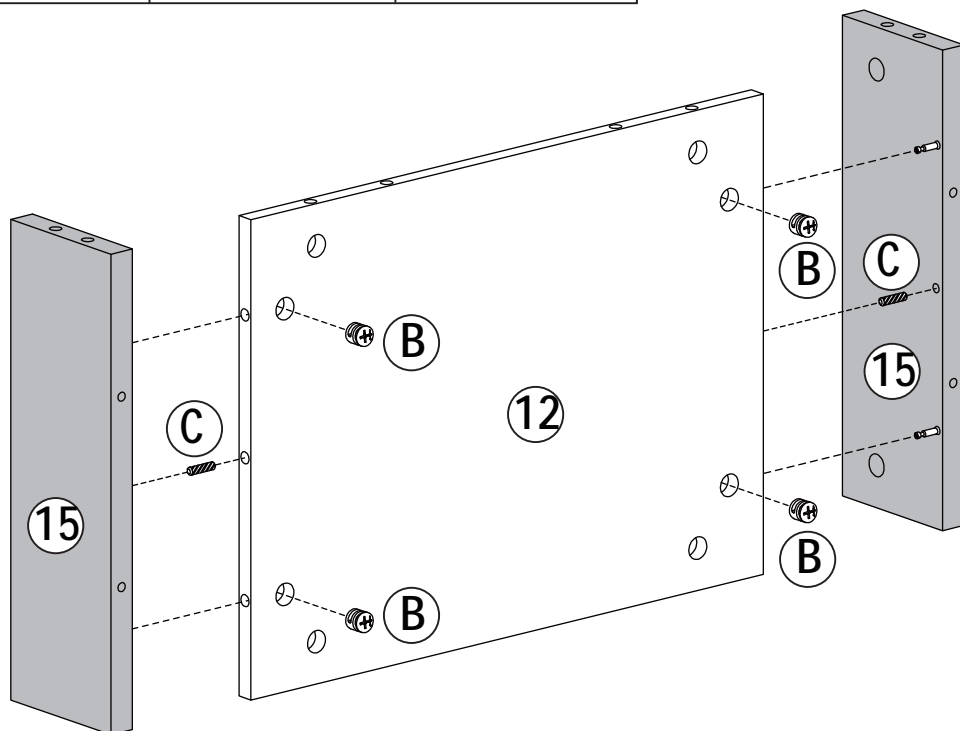

Schritt 12

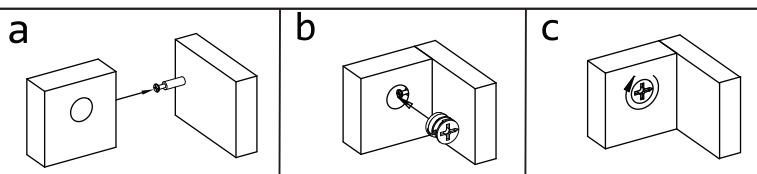

- ⓑ X 1
- ⓑ X 2
- ⓒ X 4

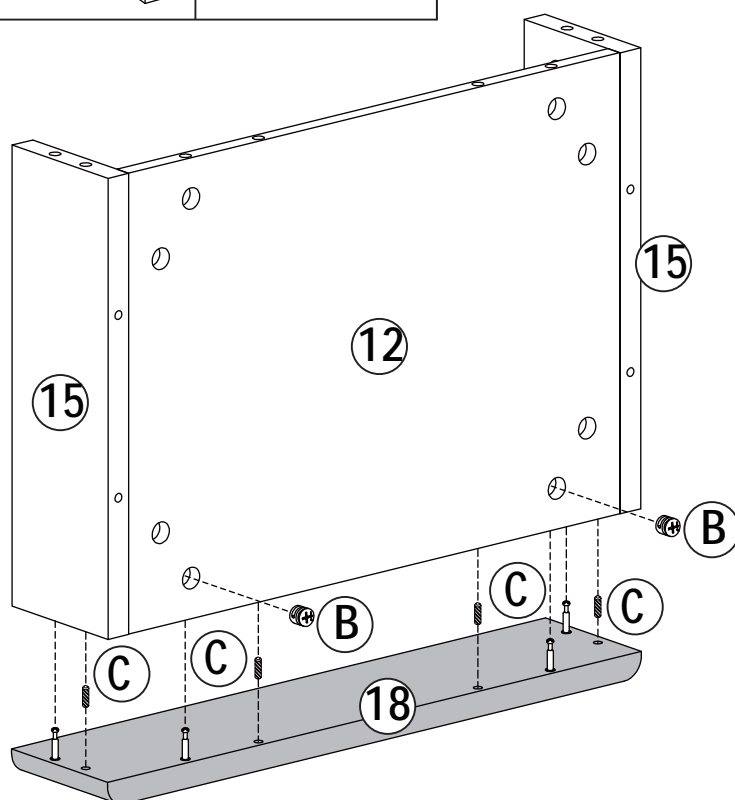

INSTALLATIONSANLEITUNG

Schritt 13

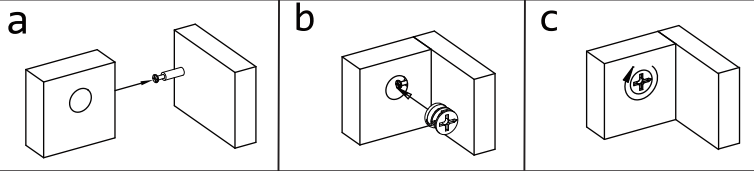

①⑥ X 1

①B X 2

①C X 4

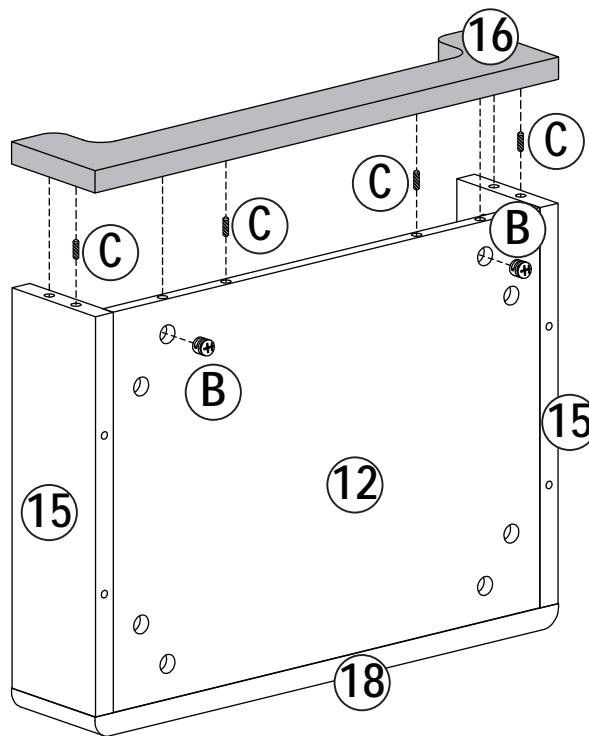

Schritt 14

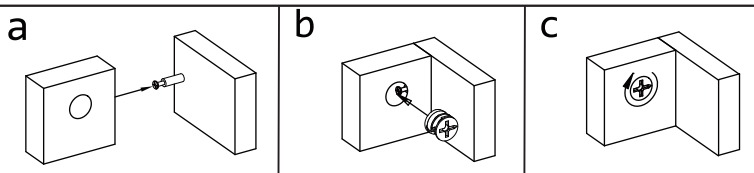

①B X 4

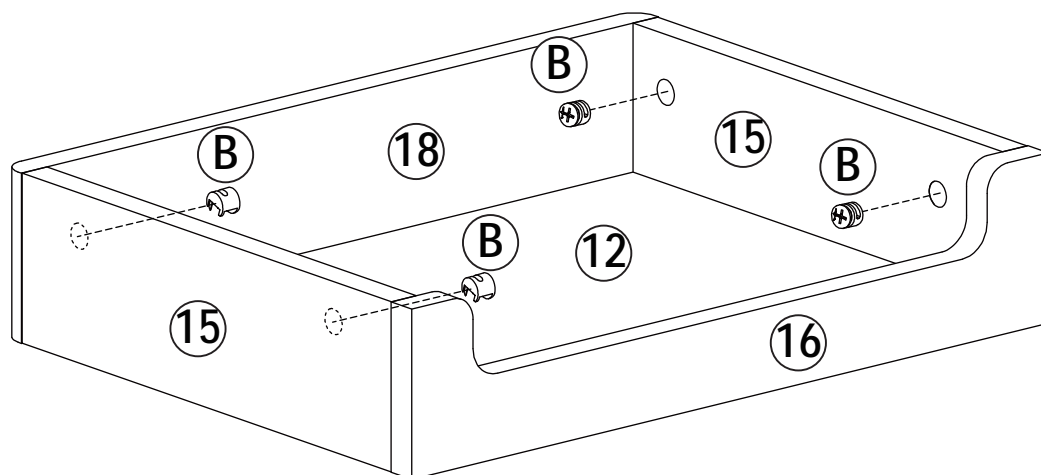

INSTALLATIONSANLEITUNG

Schritt 15



Ziehen Sie die Schrauben nicht fest, bis Schritt 18 fertig ist.

①⑨ X 1

①① X 6

①① X 2

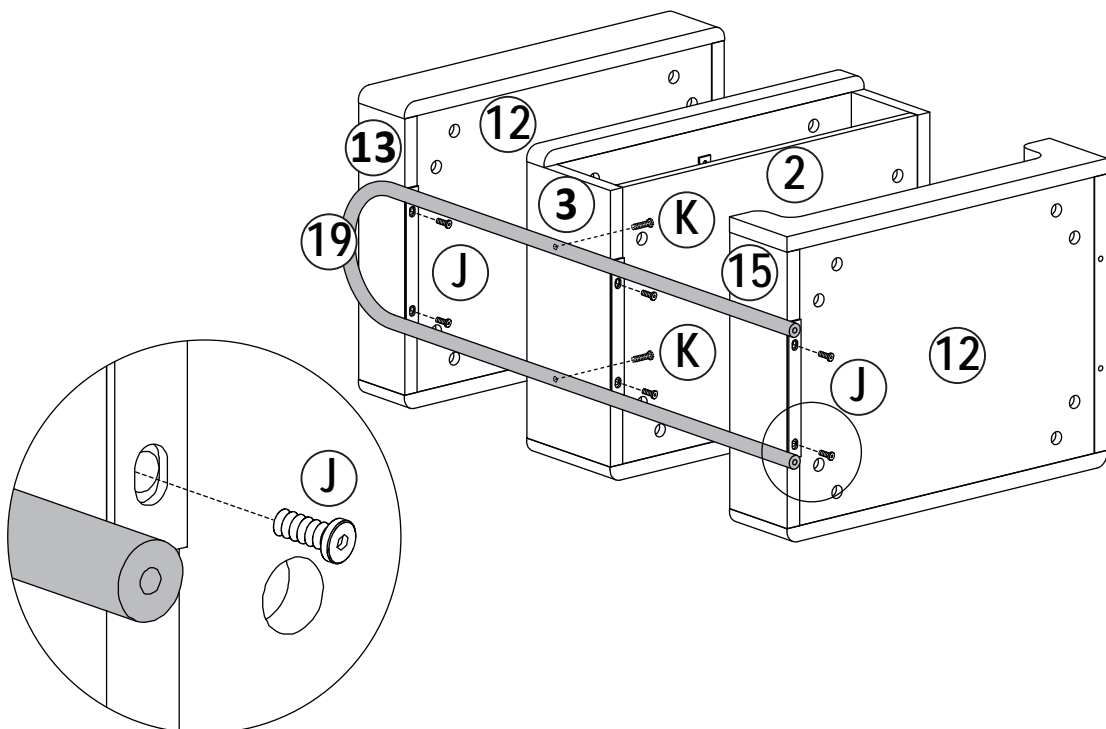

Schritt 16



Ziehen Sie die Schrauben nicht fest, bis Schritt 18 fertig ist.

①⑨ X 1

①① X 6

①① X 2

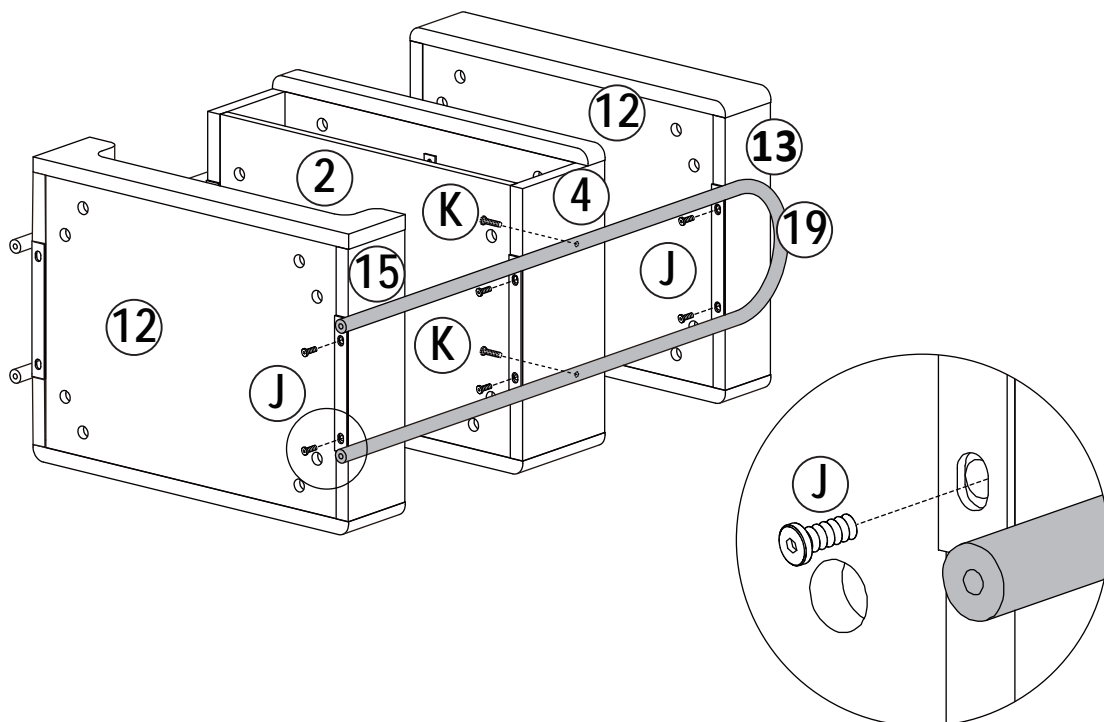

INSTALLATIONSANLEITUNG

Schritt 17



Ziehen Sie die Schrauben nicht fest, bis Schritt 18 fertig ist.

⑰ X 1

Ⓚ X 4

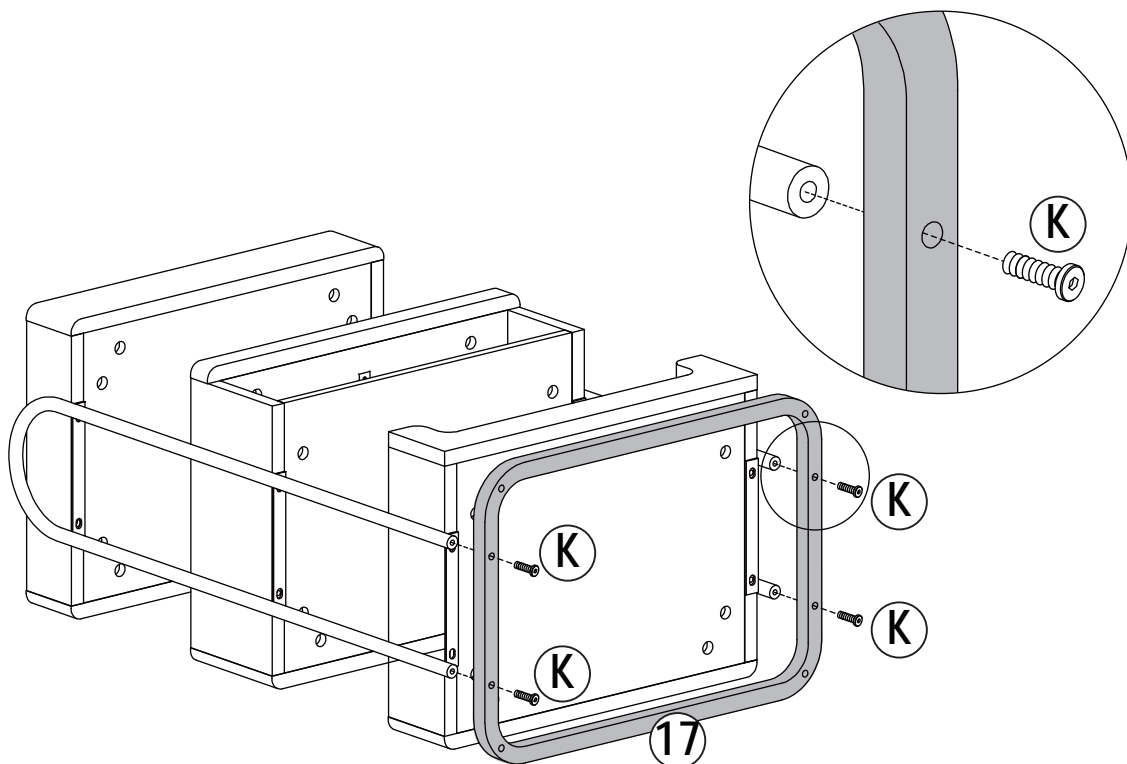

Schritt 18



Ziehen Sie alle Schrauben fest.

ⓐ X 1

ⓐ X 4

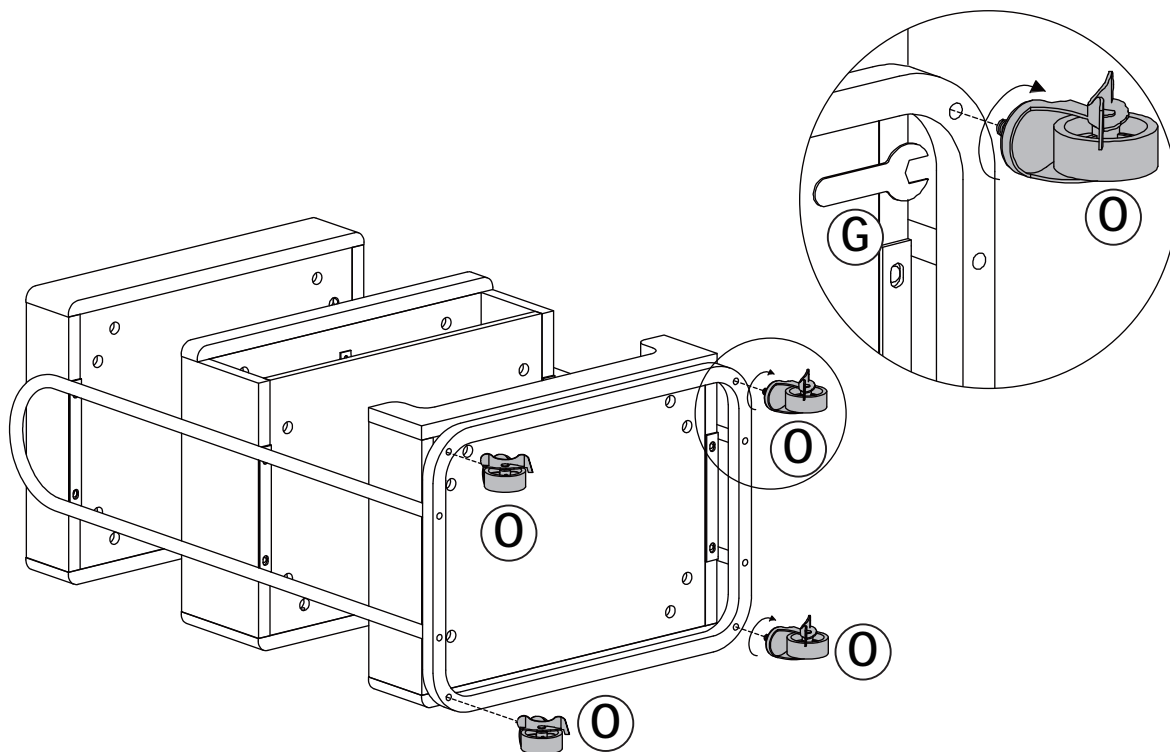

INSTALLATIONSANLEITUNG

Schritt 19

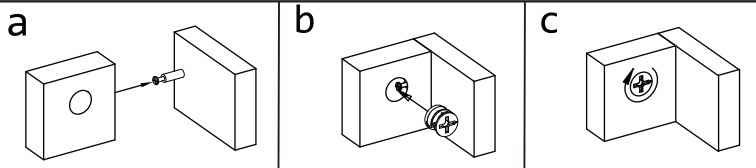

- ⑦ X 1
- ⑧ X 1
- ⑨ X 1
- ⑩ X 1
- ⑪ X 1
- Ⓐ X 4
- Ⓑ X 4
- Ⓔ X 4
- Ⓕ X 1
- Ⓖ X 1

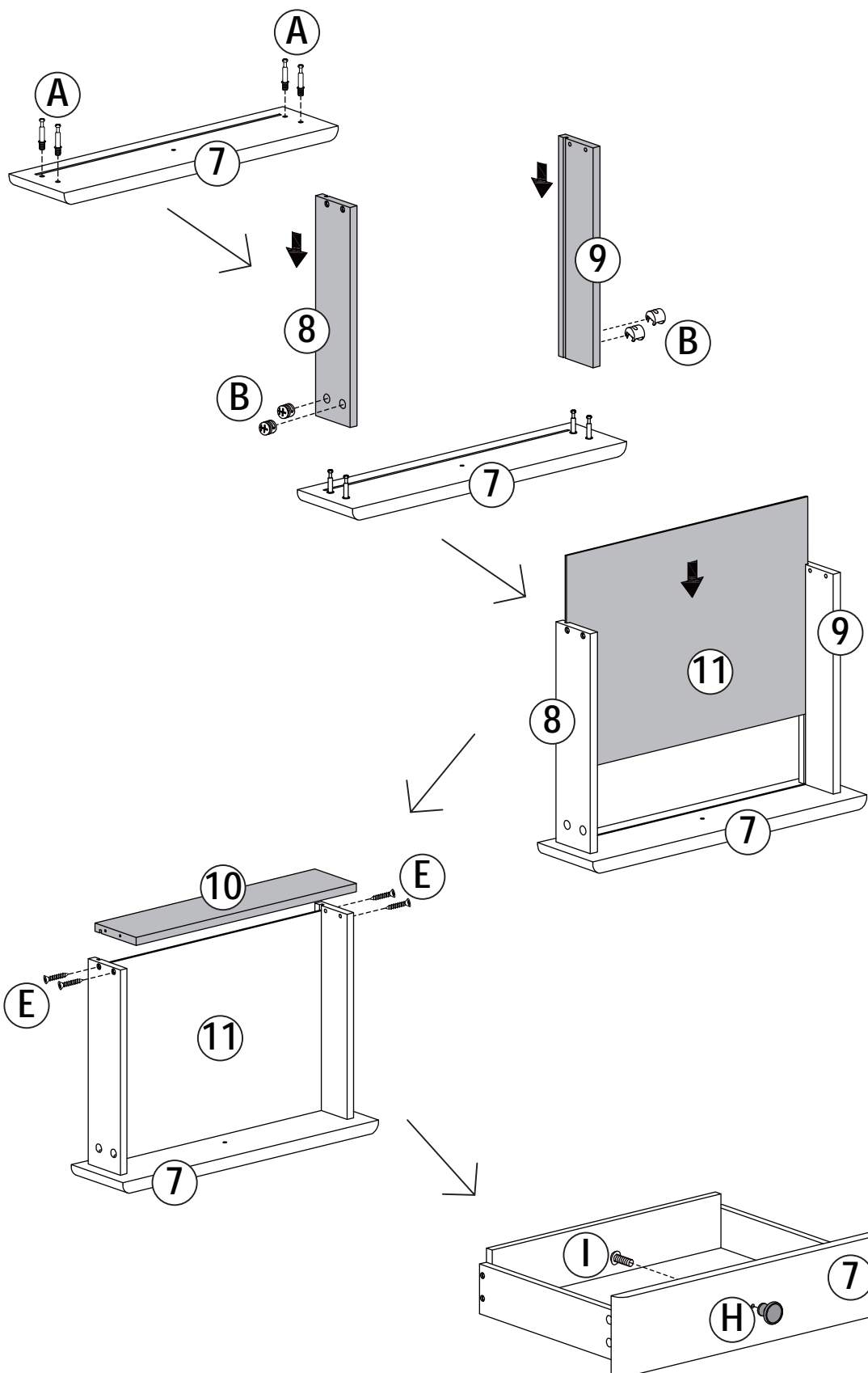

INSTALLATIONSANLEITUNG

Schritt 20

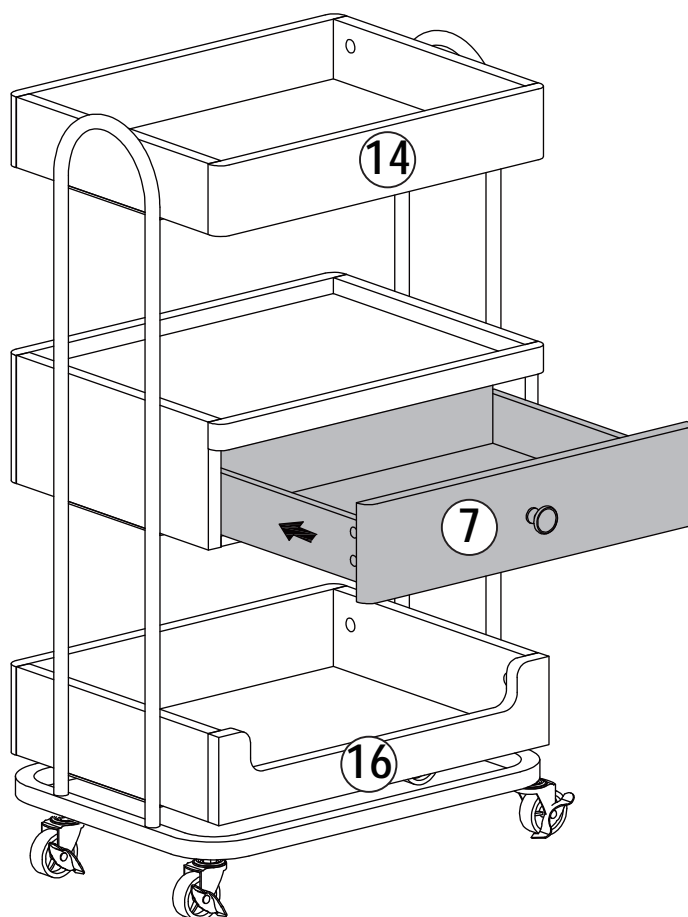

Schritt 21

Ⓜ X 2

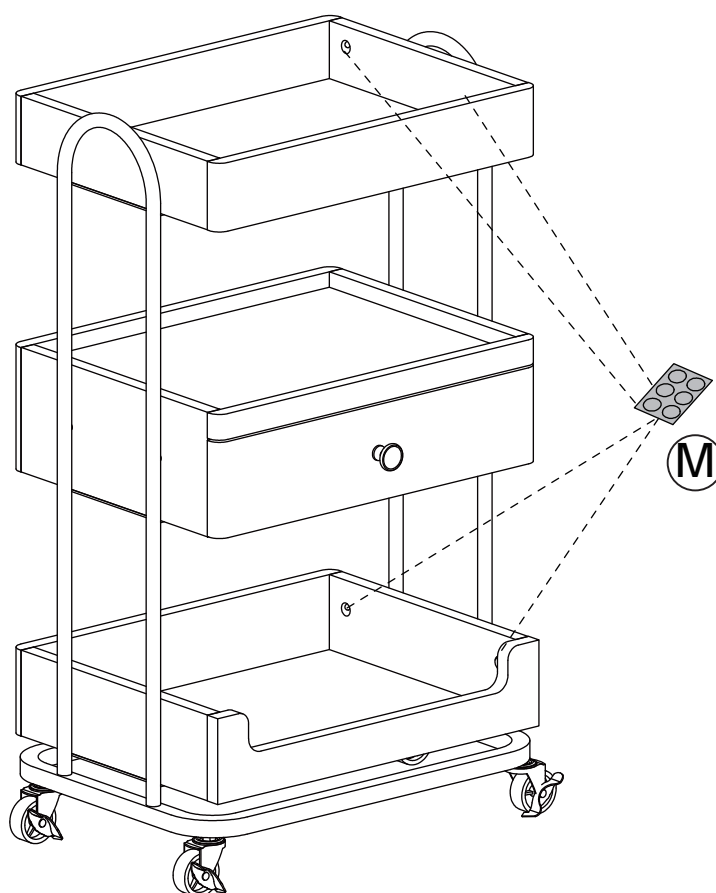

INSTALLATIONSANLEITUNG

Schritt 22

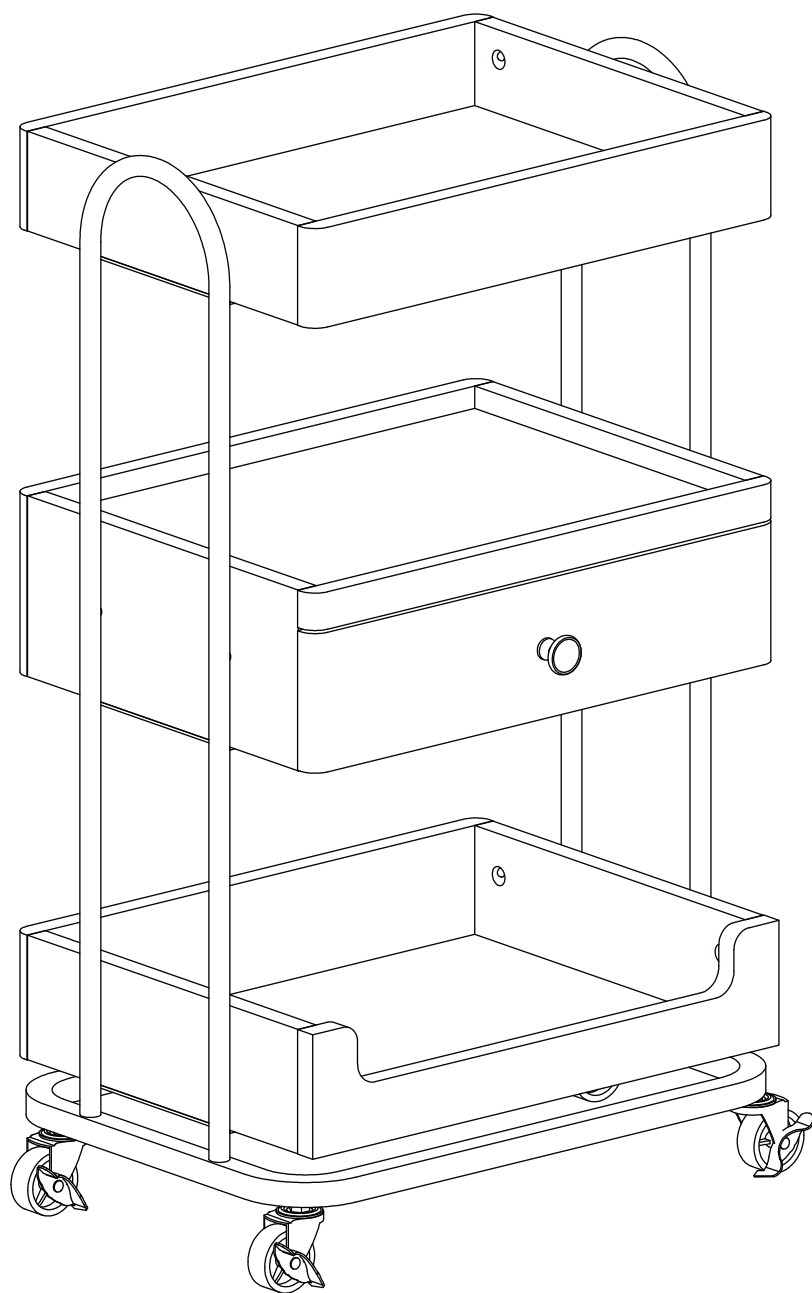

MCOMBO KUNDENDIENST

Ist das Produkt vollständig erhalten? Ist die Installation und Nutzung reibungslos verlaufen?

Wenn Sie Fragen oder Anregungen haben, setzen Sie sich bitte rechtzeitig mit uns in Verbindung. Wir werden unser Bestes versuchen, um das Problem zu lösen.

Haben Sie spezielle Anforderungen an Größe, Farbe, Stil, Material oder andere Aspekte Ihres Produkts?

Zögern Sie nicht, uns zu kontaktieren, wir verstehen Ihre Bedürfnisse gerne und bieten Ihnen bessere Produkte.

	0049-(0)21511561192
	pfillo.de@gmail.com (innerhalb 24h)
	Kreuzweg 60, 47809 Krefeld, Deutschland

