

NAGELTISCH

— MONTAGEANLEITUNG —

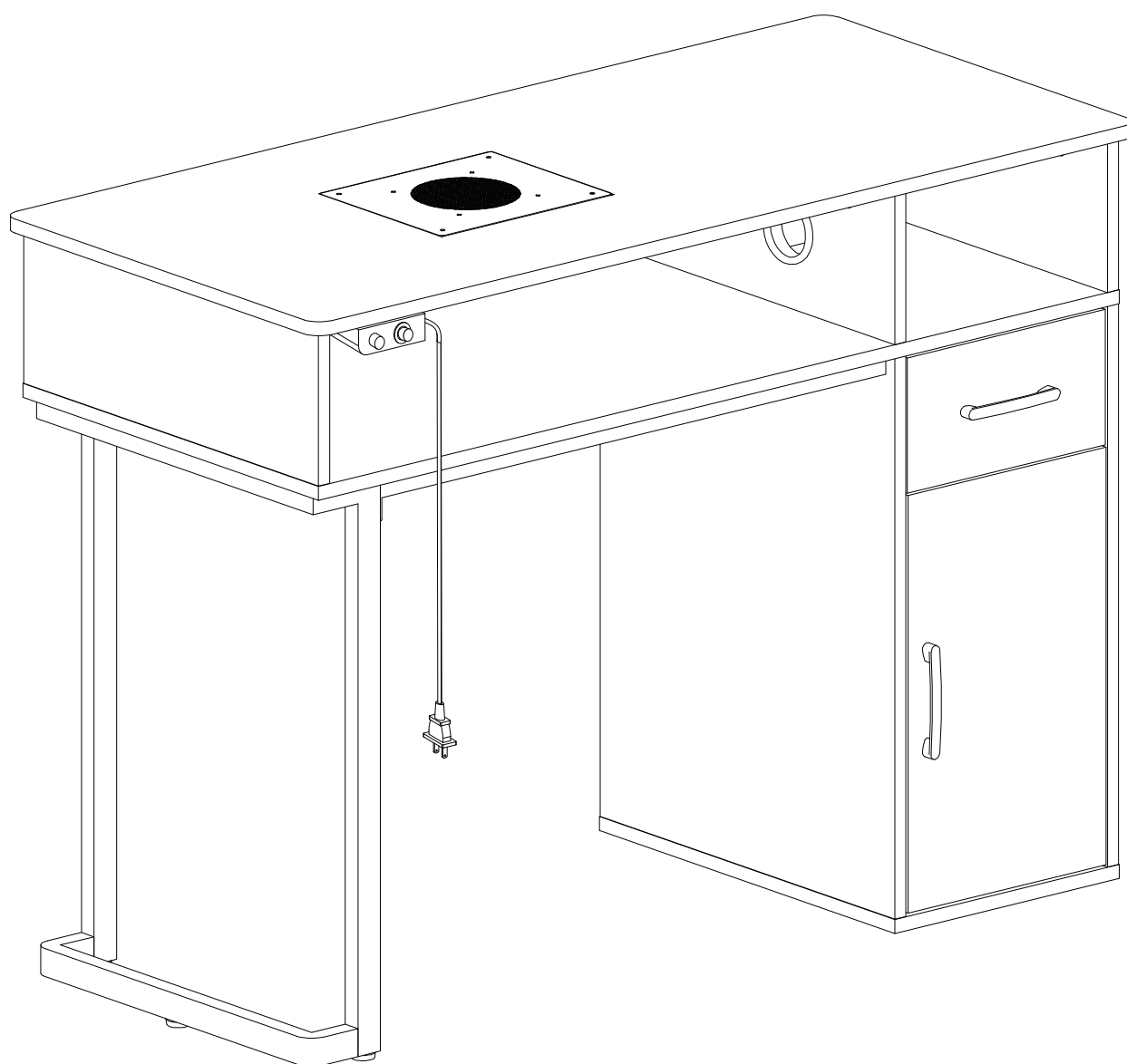

SICHERHEITSHINWEISE



Lesen und befolgen Sie die Informationen im Benutzerhandbuch.



Bitte halten Sie Kinder aus Sicherheitsgründen von kleinen Komponenten fern.



Das Produkt soll in einer trockenen Umgebung verwendet werden.



Bitte beachten Sie, dass Holz nicht kratzfest ist.



Wasserflecken und Flecken soll rechtzeitig gereinigt werden.



Platzieren Sie keine übergewichtigen Gegenstände.



Bitte behandeln Sie Holz und anderes Zubehör sachgemäß.

— HAFTUNGSAUSSCHLUSS —

Wir bitten Sie, diese Anleitung vollständig zu lesen, bevor Sie den Artikel zusammenbauen und in Betrieb nehmen. Wir sind nicht und können nicht für Schäden oder Verletzungen verantwortlich gemacht werden, die durch unsachgemäße oder unsichere Verwendung des Artikels entstehen. Wir lehnen ausdrücklich die Verantwortung für Körperverletzungen oder Sachschäden ab, die bei einer Verwendung auftreten können, die nicht den geltenden Bundes-, Landes- oder lokalen Gesetzen oder Verordnungen entspricht. Bitte bewahren Sie dieses Handbuch für zukünftige Bezugnahme auf.

INSTALLATIONSVORBEREITUNG

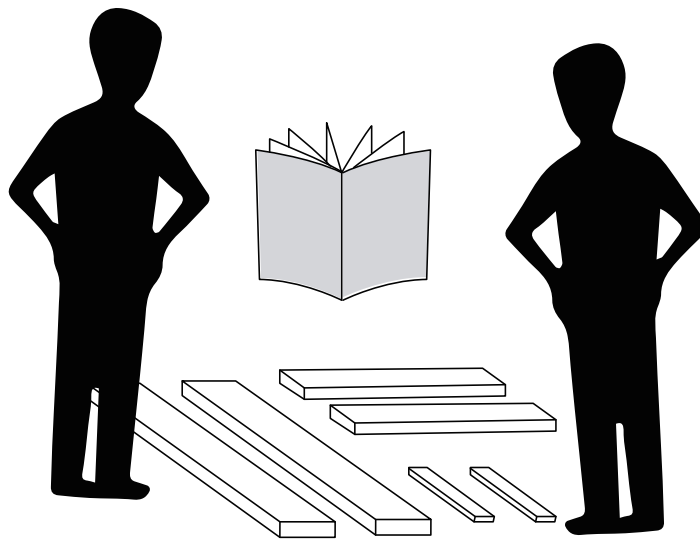

- Bitte bereiten Sie einen Teppich oder eine Matte vor, um Ihren Boden zu schützen. Sie müssen alle Zubehörteile auslegen.
- Bitte bereiten Sie ein Paar Handschuhe vor, um Kratzer durch scharfes Holzsägemehl zu vermeiden, das während der Installation auftreten kann.
- Bitte öffnen Sie alle Kartons, um zu überprüfen, ob das Zubehör vollständig und in gutem Zustand ist.
- Die Box enthält einige kleine Komponenten, bitte platzieren Sie sie vor der Installation richtig, um sie von Kindern fernzuhalten und die Sicherheit zu gewährleisten.
- Wenn Sie Elektrowerkzeuge verwenden müssen, um dieses Produkt zu installieren, stellen Sie bitte die Geschwindigkeit im Voraus auf niedrige Geschwindigkeit ein.
- Richten Sie bei der Installation bitte alle Löcher aus, bevor Sie alle Schrauben festziehen.

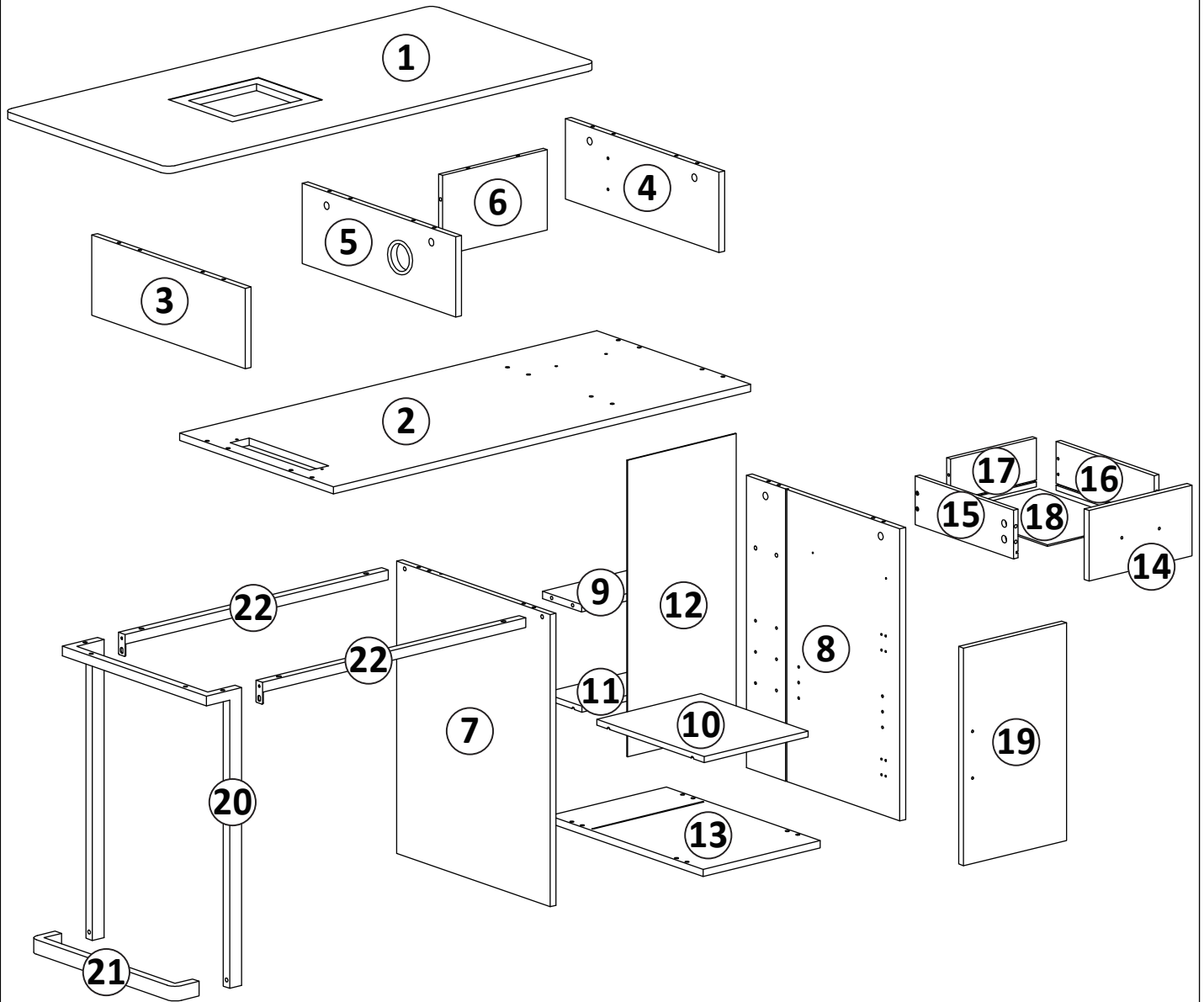

ZUBEHÖRTEILE

①

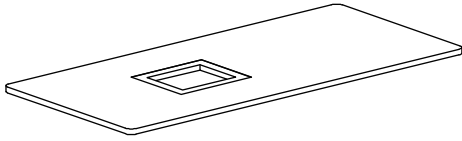

1100*500mm x1

②

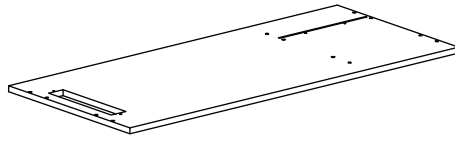

1070*470mm x1

③

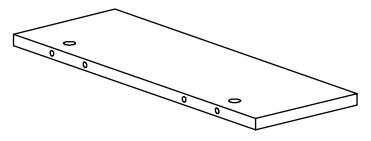

165*469mm x1

④

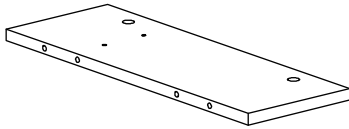

165*469mm x1

⑤

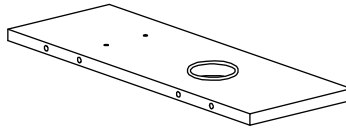

165*469mm x1

⑥

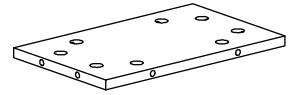

165*269mm x1

⑦

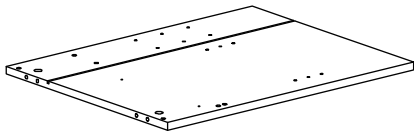

600*469mm x1

⑧

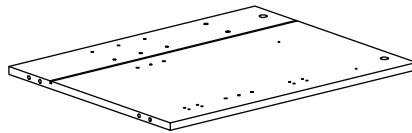

600*469mm x1

⑨

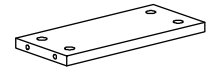

269*119mm x1

⑩

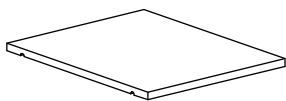

267*326mm x1

⑪



267*118mm x1

⑫

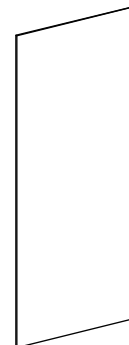

609*278mm x1

ZUBEHÖRTEILE

13

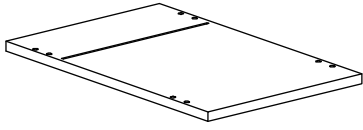

300*470mm x1

14

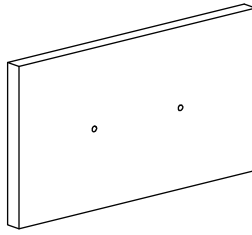

264*145mm x1

15

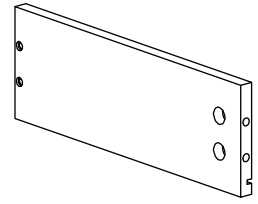

300*100mm x1

16

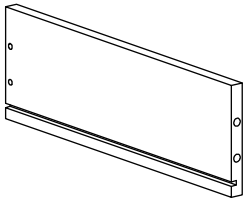

300*100mm x1

17

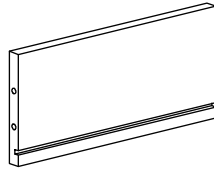

220*100mm x1

18

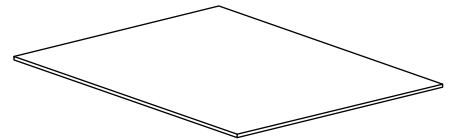

229*297mm x1

19

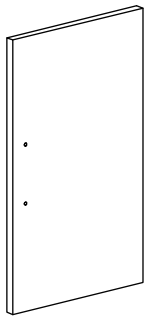

447*264mm x1

20

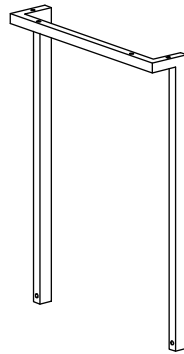

612*440mm x1

21

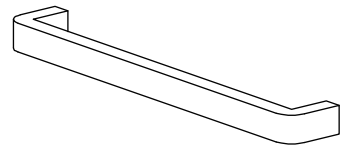

440*65mm x1

22

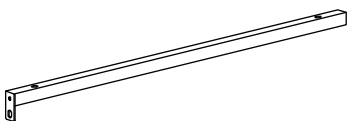

675*45mm x2

SCHRAUBENGRUPPE

A

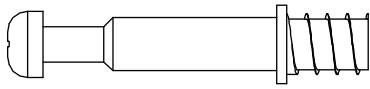

Ø6*35mm **x26**

B

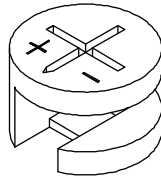

Ø15*10mm **x26**

C

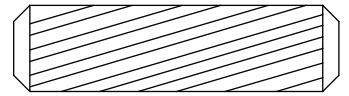

Ø8*30mm **x20**

D

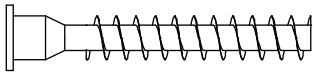

Ø7*47mm **x10**

E



M4*64mm **x1**

F

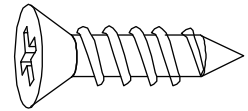

3.5*14mm **x22**

G

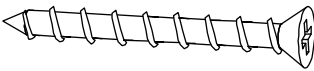

Ø4*35mm **x4**

H

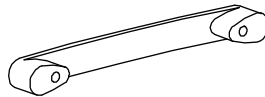

122*13*21mm **x2**

I

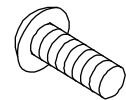

M4*18mm **x4**

J

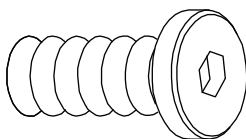

M6*12mm **x2**

K

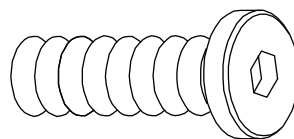

M6*30mm **x8**

L

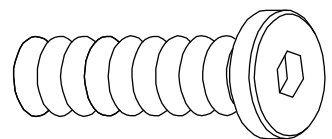

M6*35mm **x2**

SCHRAUBENGRUPPE

M

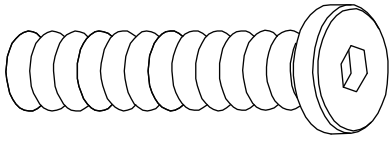

M6*50mm x2

N

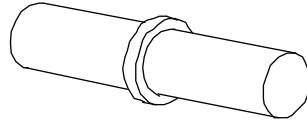

Ø5*13mm x8

O

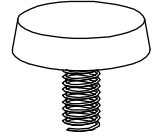

M6*22mm x3

P

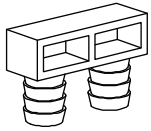

27*10*19mm x1

Q

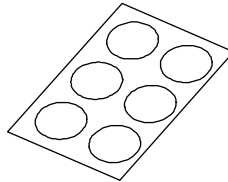

Ø20mm x3

R

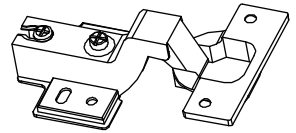

x2

S

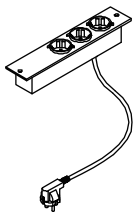

x1

CL

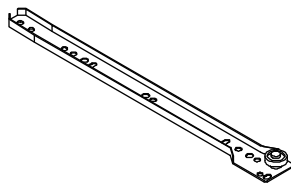

L300mm x1

CR

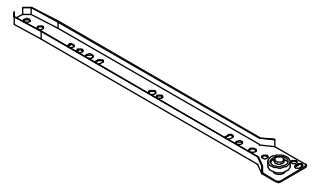

L300mm x1

DL

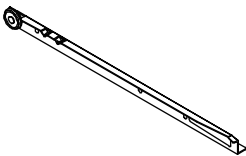

L300mm x1

DR

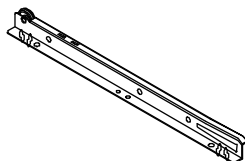

L300mm x1

T

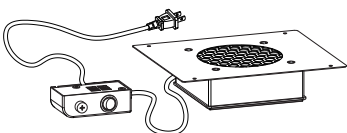
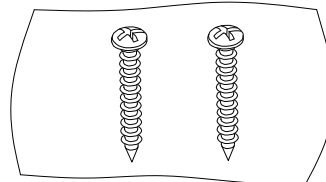
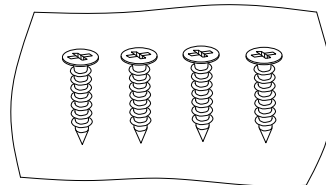
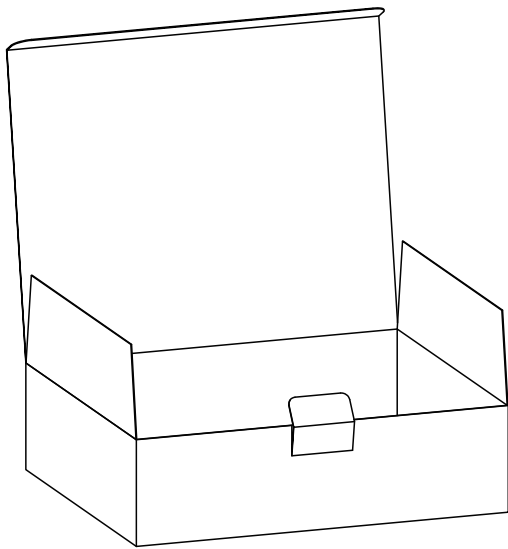
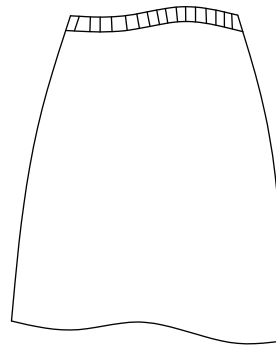
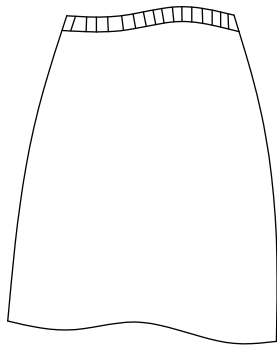
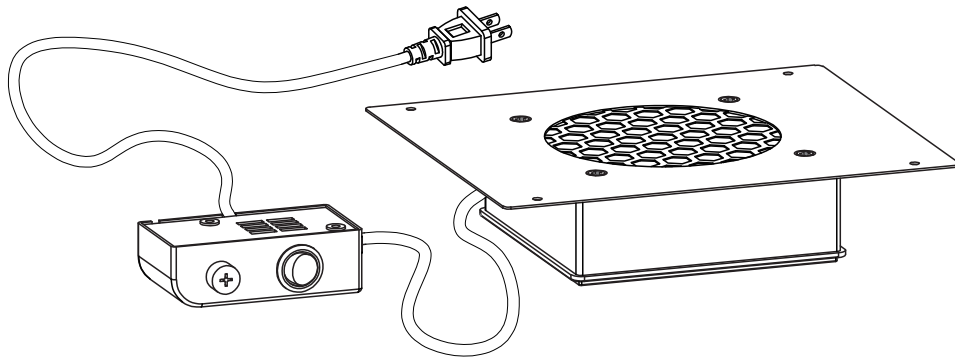

x1

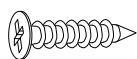

Ø3.5*12mm x4



Ø3*14mm x2

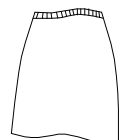

x2

INSTALLATIONSANLEITUNG

Schritt 1

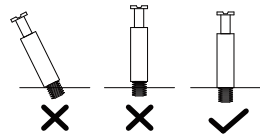

#A müssen vollständig verschraubt werden.

- ① X 1
- ② X 1
- ④ X 1
- ⑤ X 1
- ⑦ X 1
- ⑧ X 1
- Ⓐ X 22

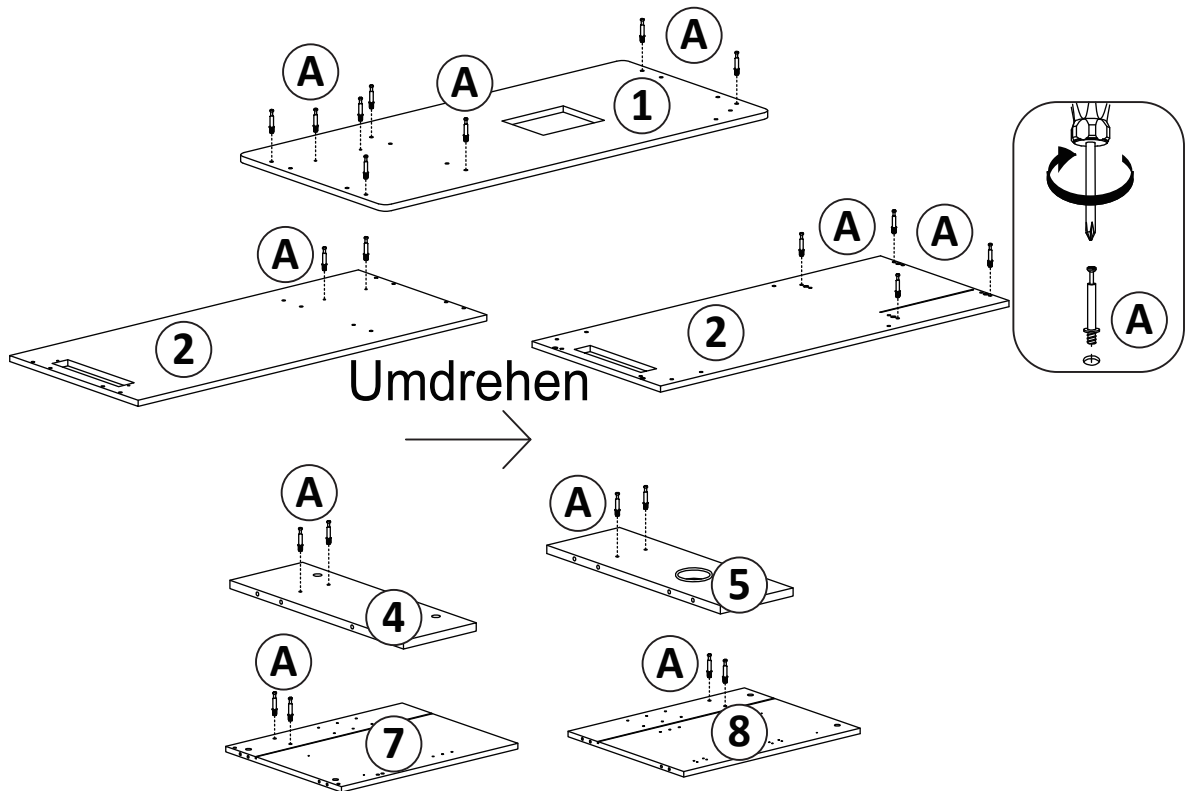

Schritt 2

- ⑦ X 1
- ⑧ X 1
- Ⓕ X 4
- Ⓟ X 1
- ⒸⓁ X 1
- ⒸⓇ X 1

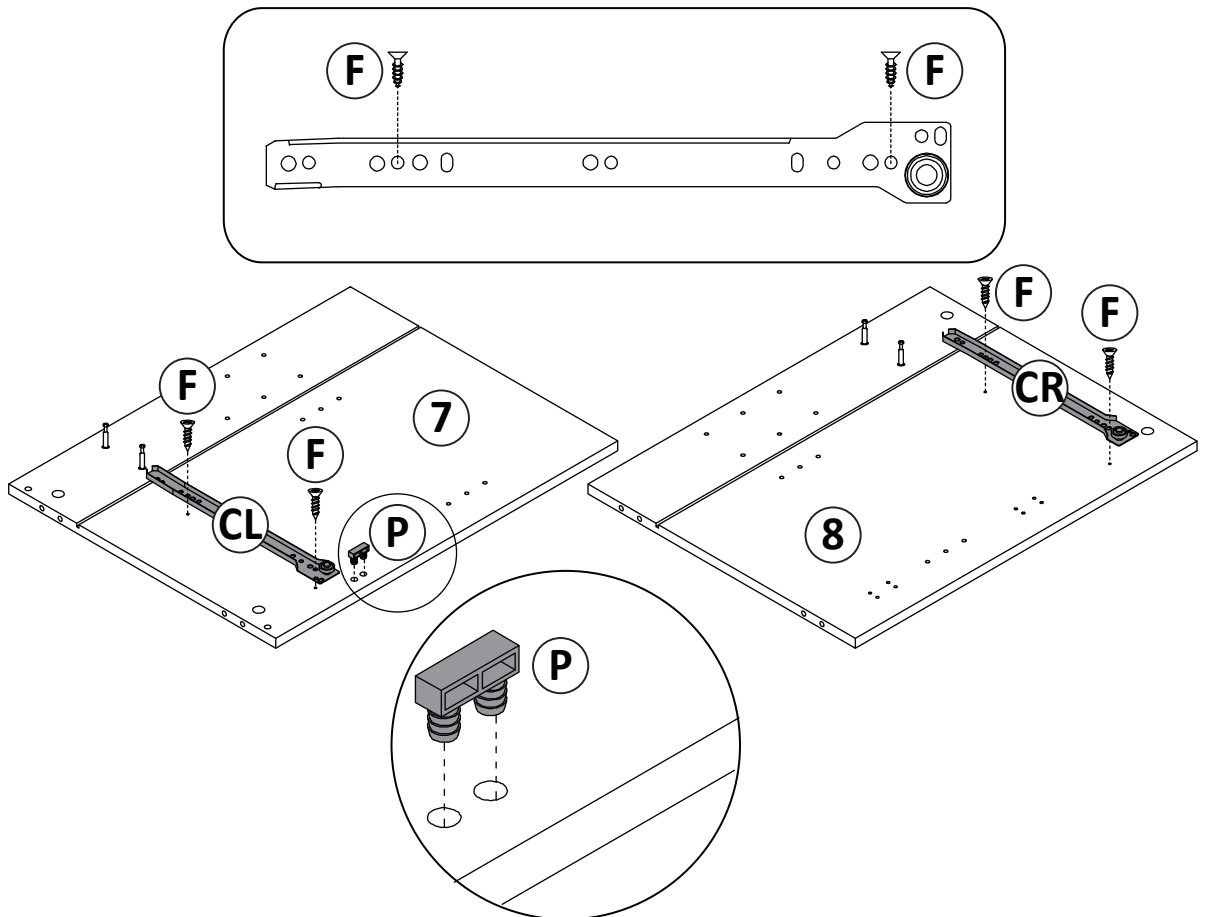

INSTALLATIONSANLEITUNG

Schritt 3

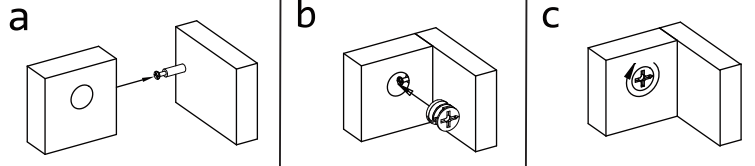

- ④ X 1
- ⑤ X 1
- ⑥ X 1
- Ⓑ X 4

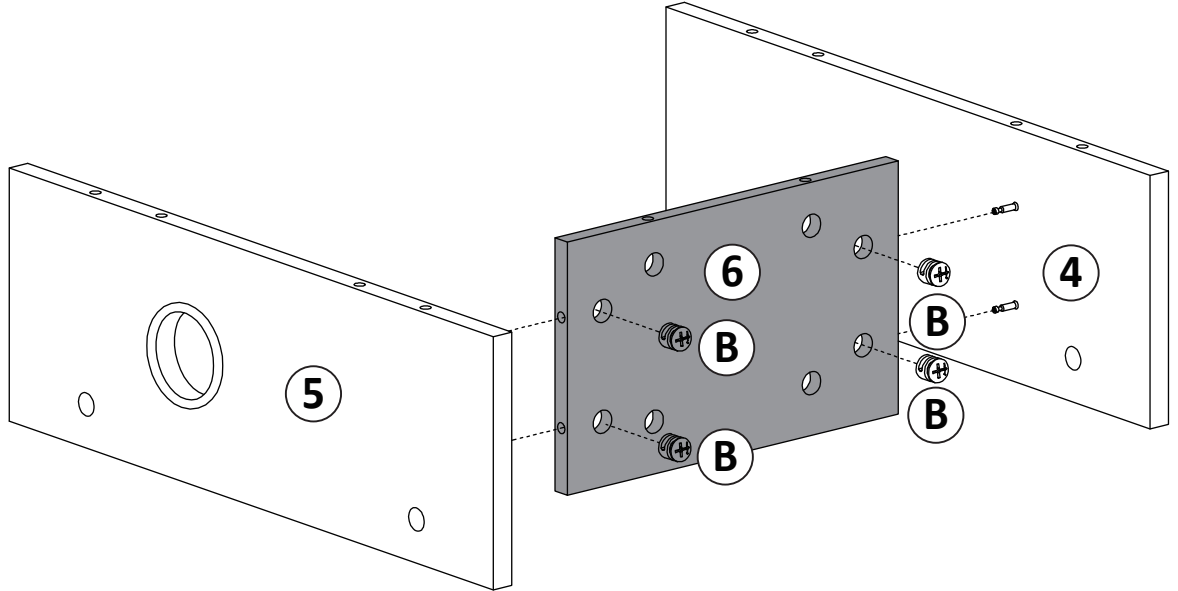

Schritt 4

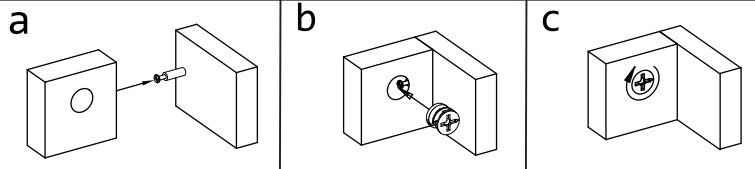

- ① X 1
- ③ X 1
- Ⓑ X 8
- Ⓒ X 6

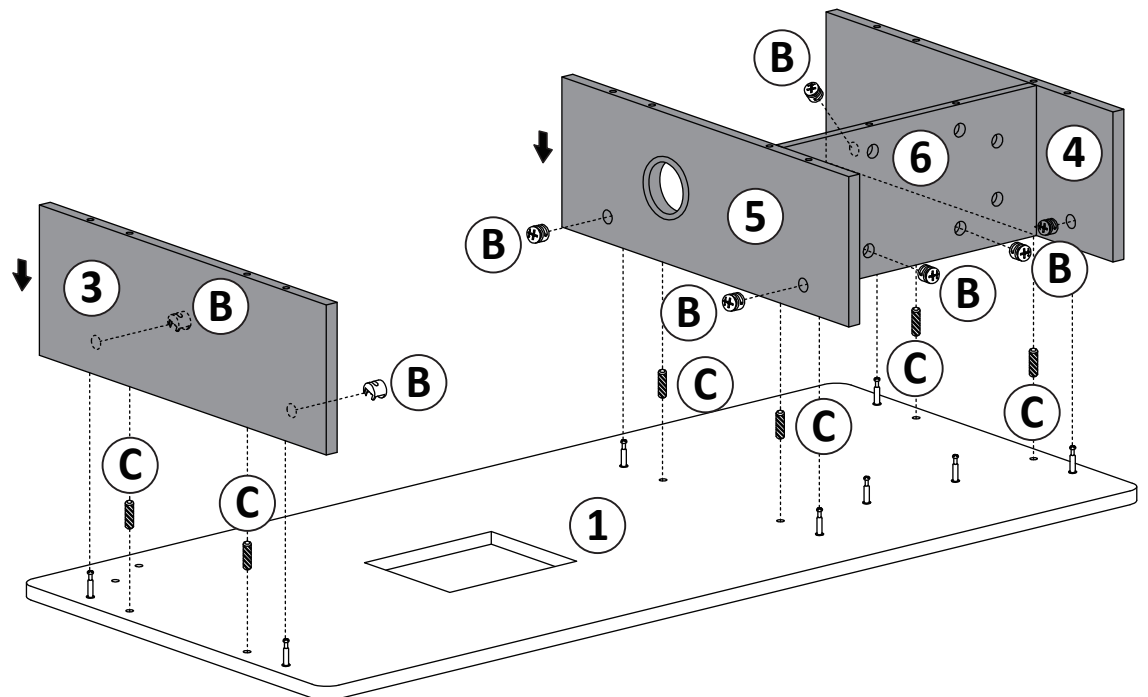

INSTALLATIONSANLEITUNG

Schritt 5

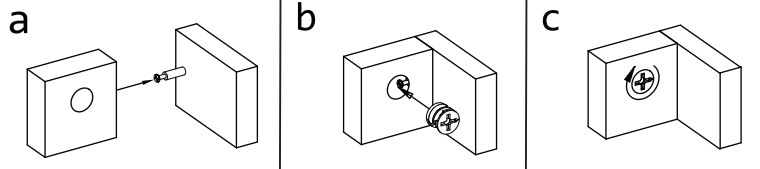

- ② X 1
- Ⓑ X 2
- Ⓒ X 6
- Ⓓ X 6
- Ⓔ X 1

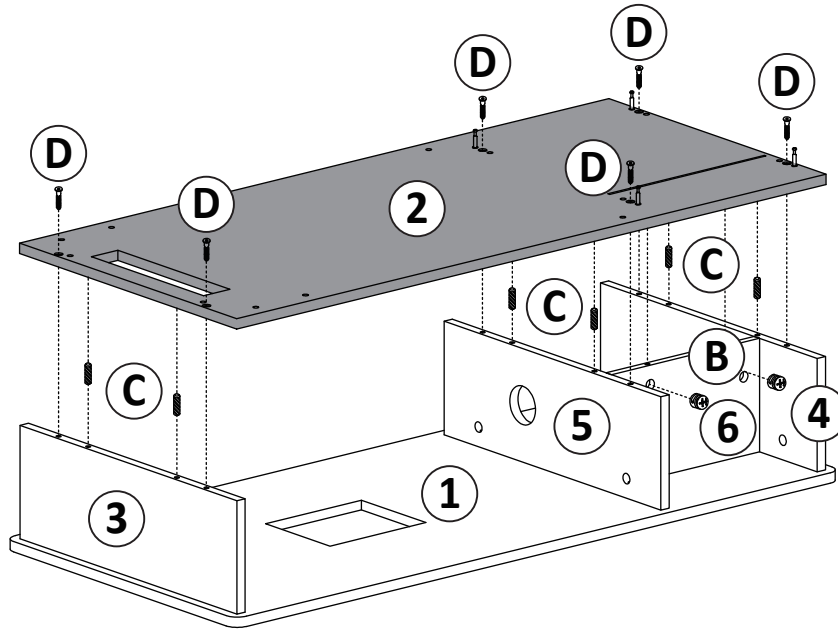

Schritt 6

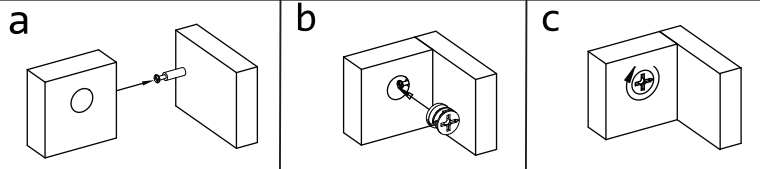

- ⑦ X 1
- ⑧ X 1
- ⑨ X 1
- Ⓑ X 4

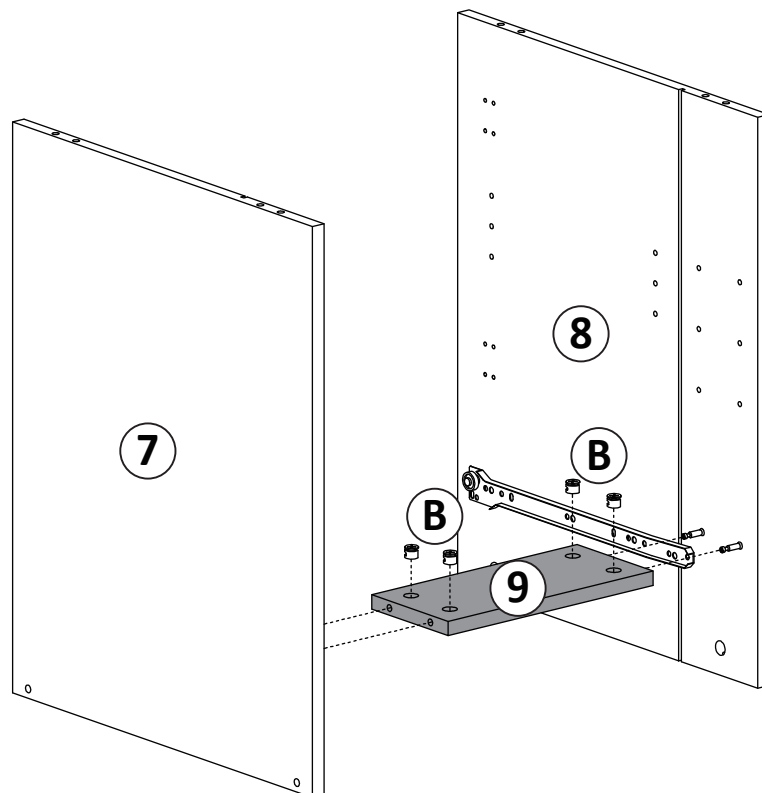

INSTALLATIONSANLEITUNG

Schritt 7

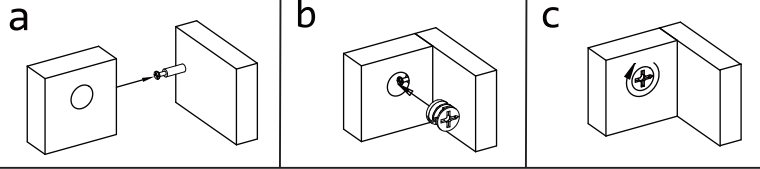

ⓑ X 4

ⓒ X 4

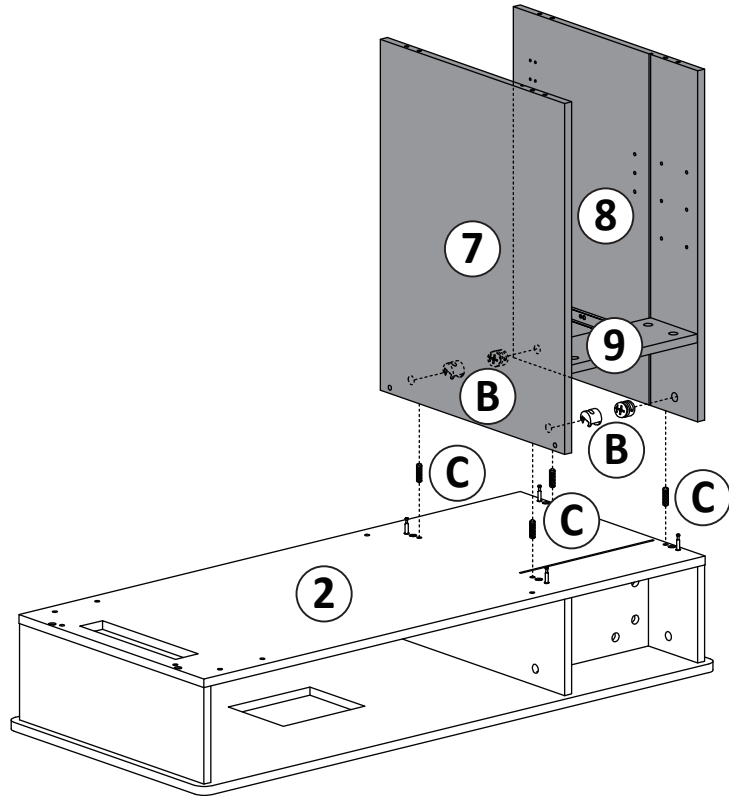

Schritt 8

⓫ X 1

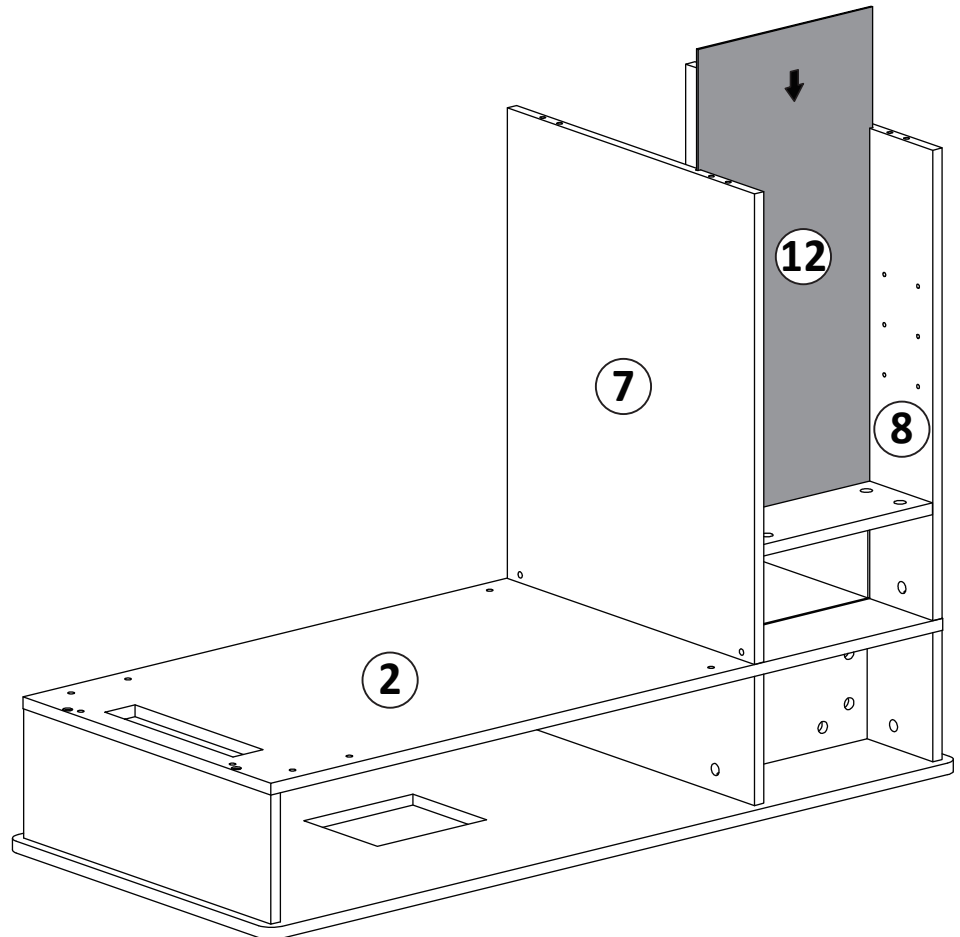

INSTALLATIONSANLEITUNG

Schritt 9

13 X 1

C X 4

D X 4

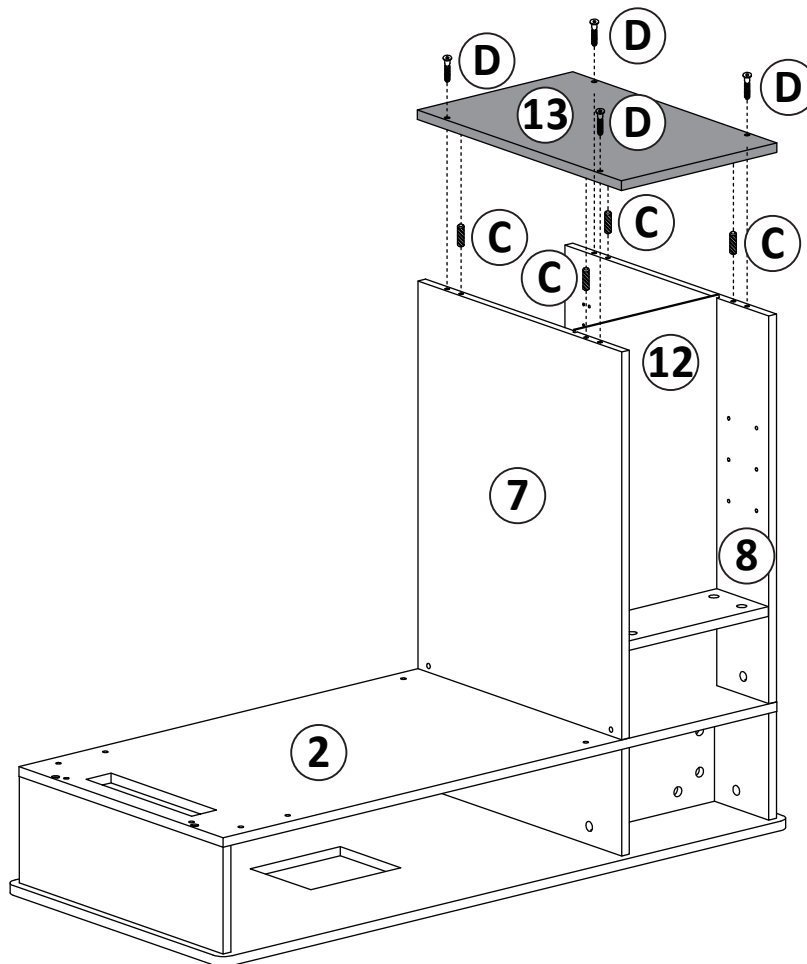

Schritt 10



Ziehen Sie die Schrauben nicht fest, bis Schritt 14 fertig ist.

22 X 2

K X 4

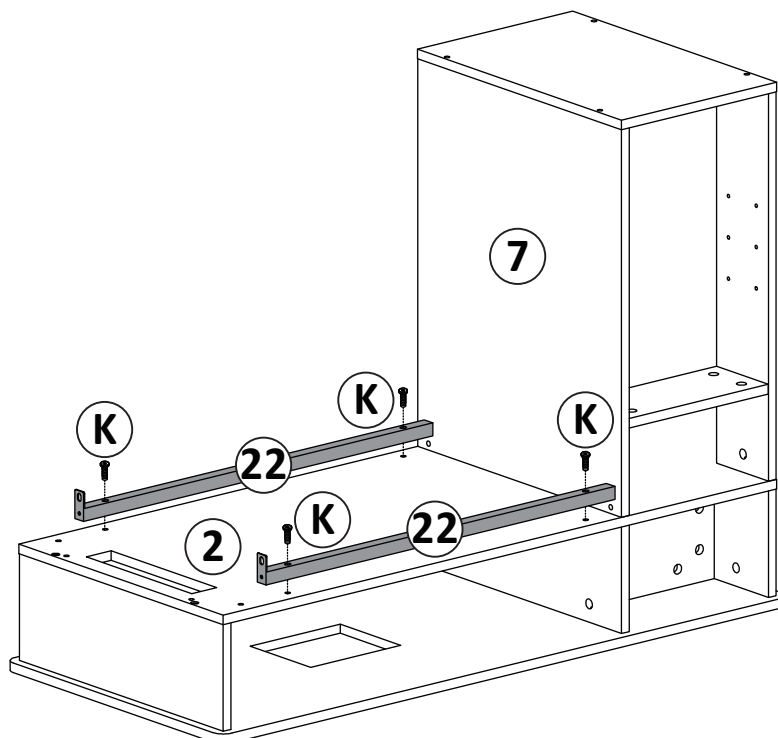

INSTALLATIONSANLEITUNG

Schritt 11



Ziehen Sie die Schrauben nicht fest, bis Schritt 14 fertig ist.

Ⓛ X 2

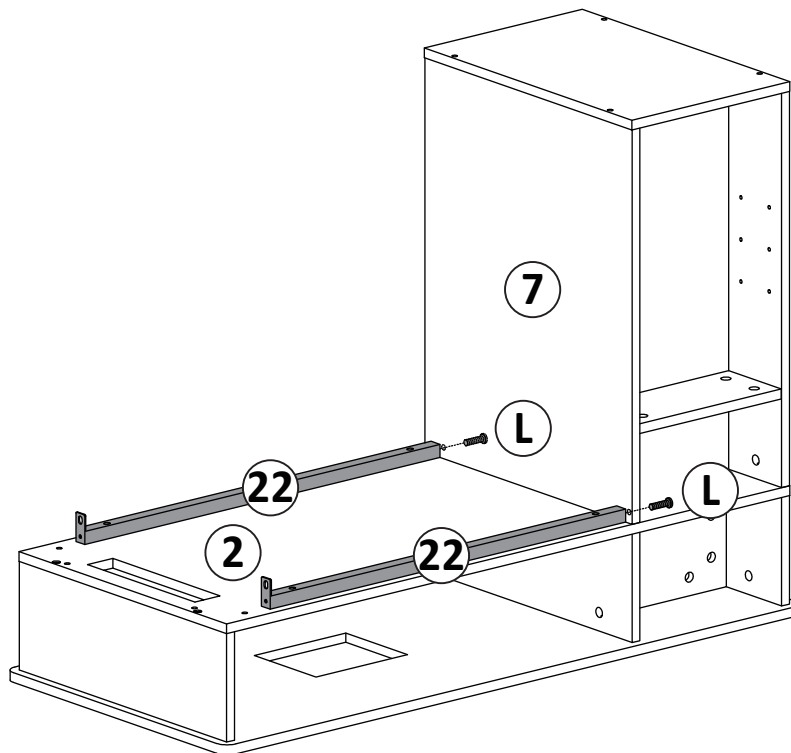

Schritt 12



Ziehen Sie die Schrauben nicht fest, bis Schritt 14 fertig ist.
Ziehen Sie die Fußstifte fest.

ⓐ X 1

ⓑ X 1

Ⓜ X 2

ⓐ X 3

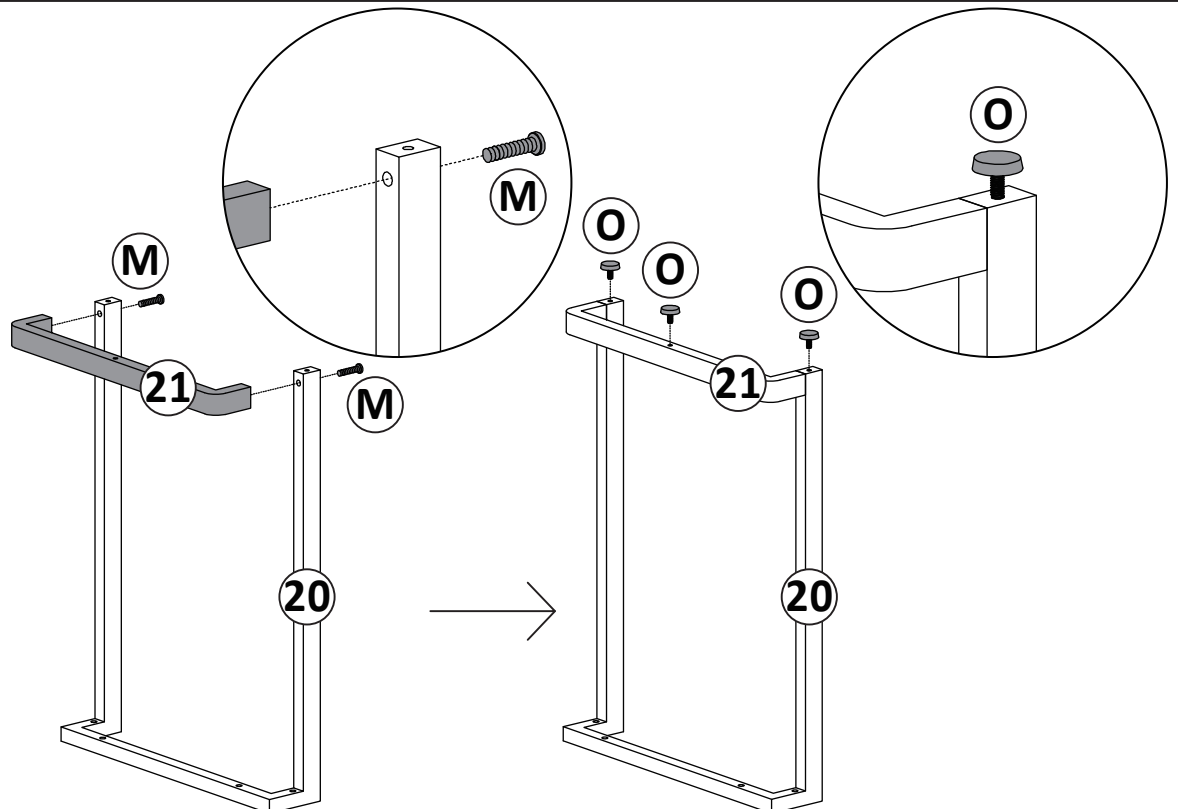

INSTALLATIONSANLEITUNG

Schritt 13



Ziehen Sie die Schrauben nicht fest, bis Schritt 14 fertig ist.

K X 4

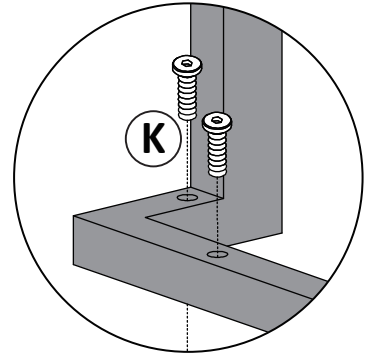
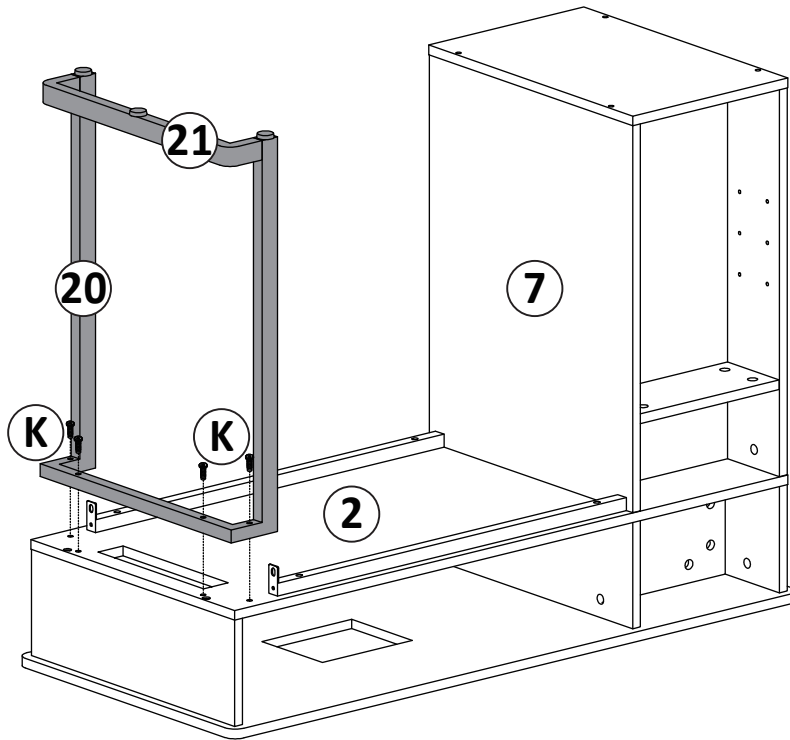

Schritt 14



Ziehen Sie alle Schrauben fest.

J X 2

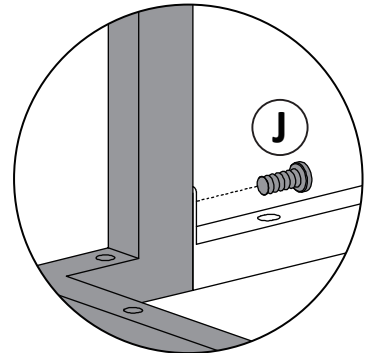
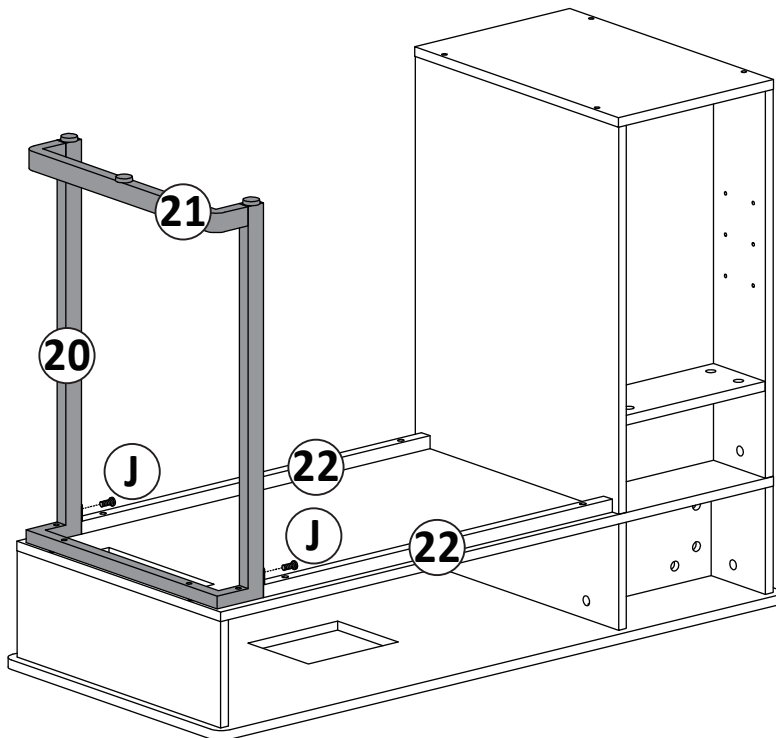

INSTALLATIONSANLEITUNG

Schritt 15

N X 4

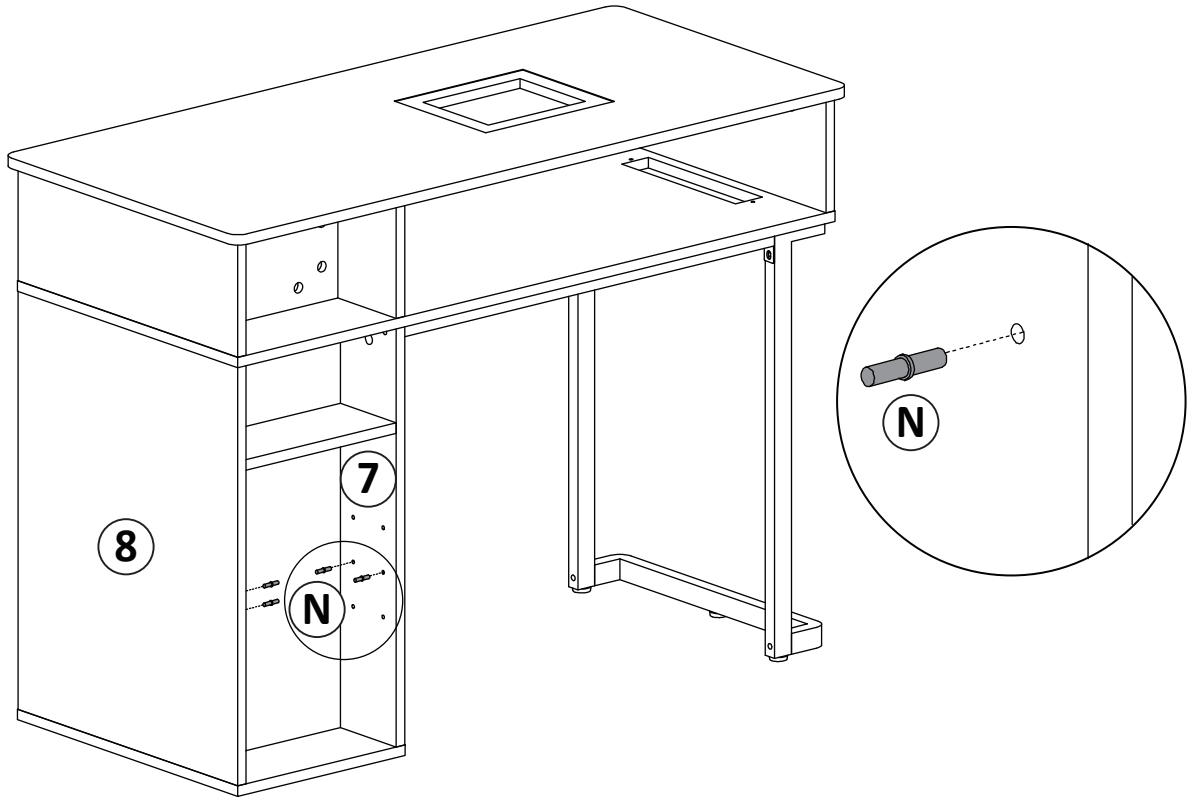

Schritt 16

11 X 1

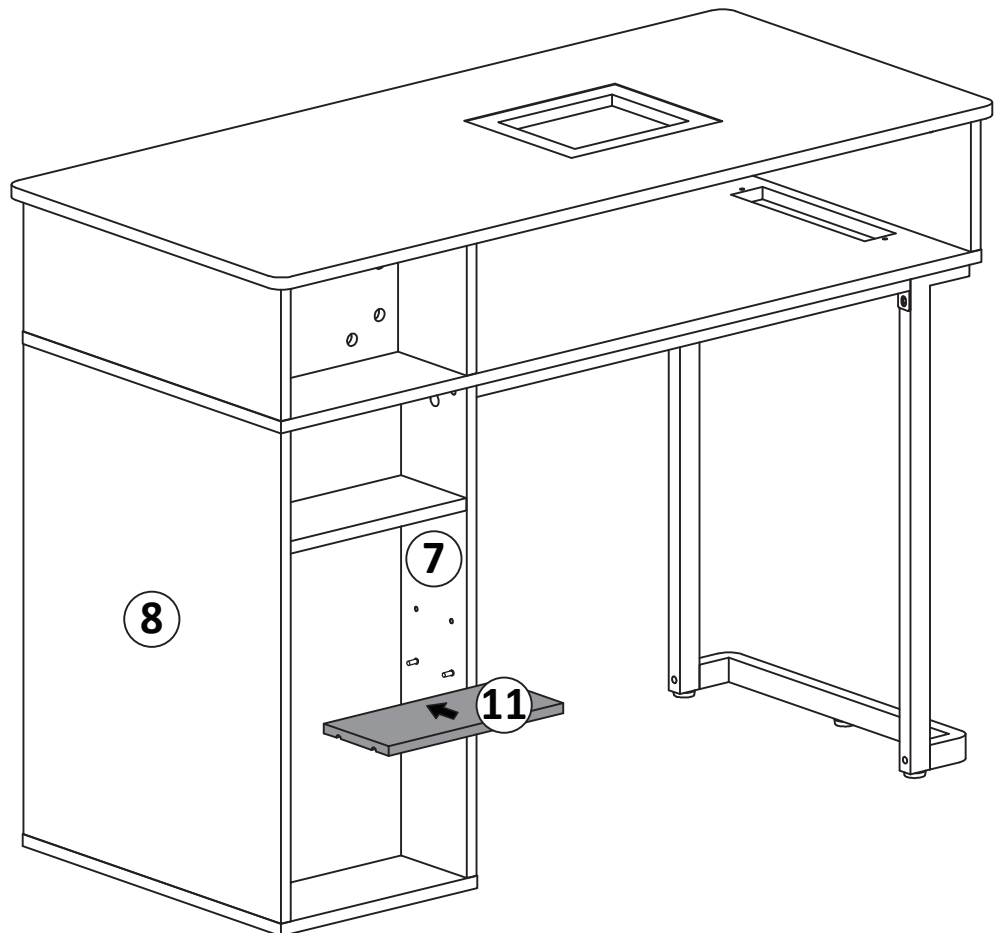

INSTALLATIONSANLEITUNG

Schritt 17

N X 4

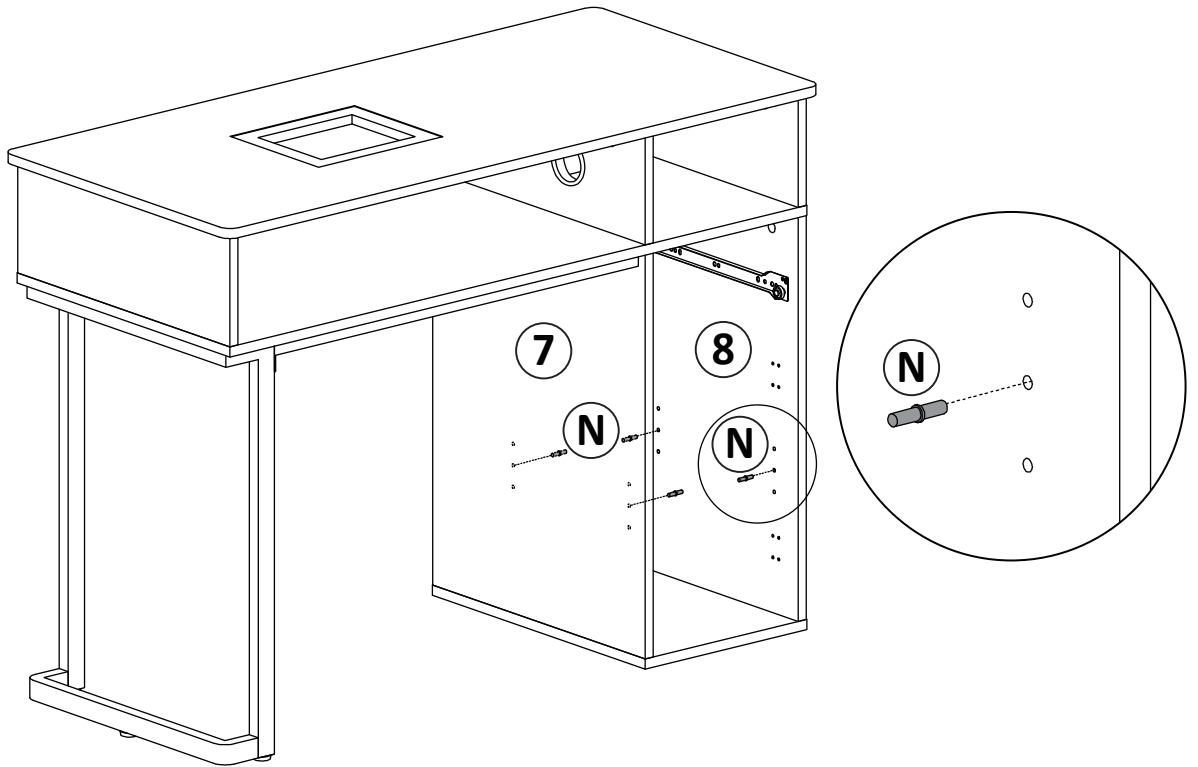

Schritt 18

10 X 1

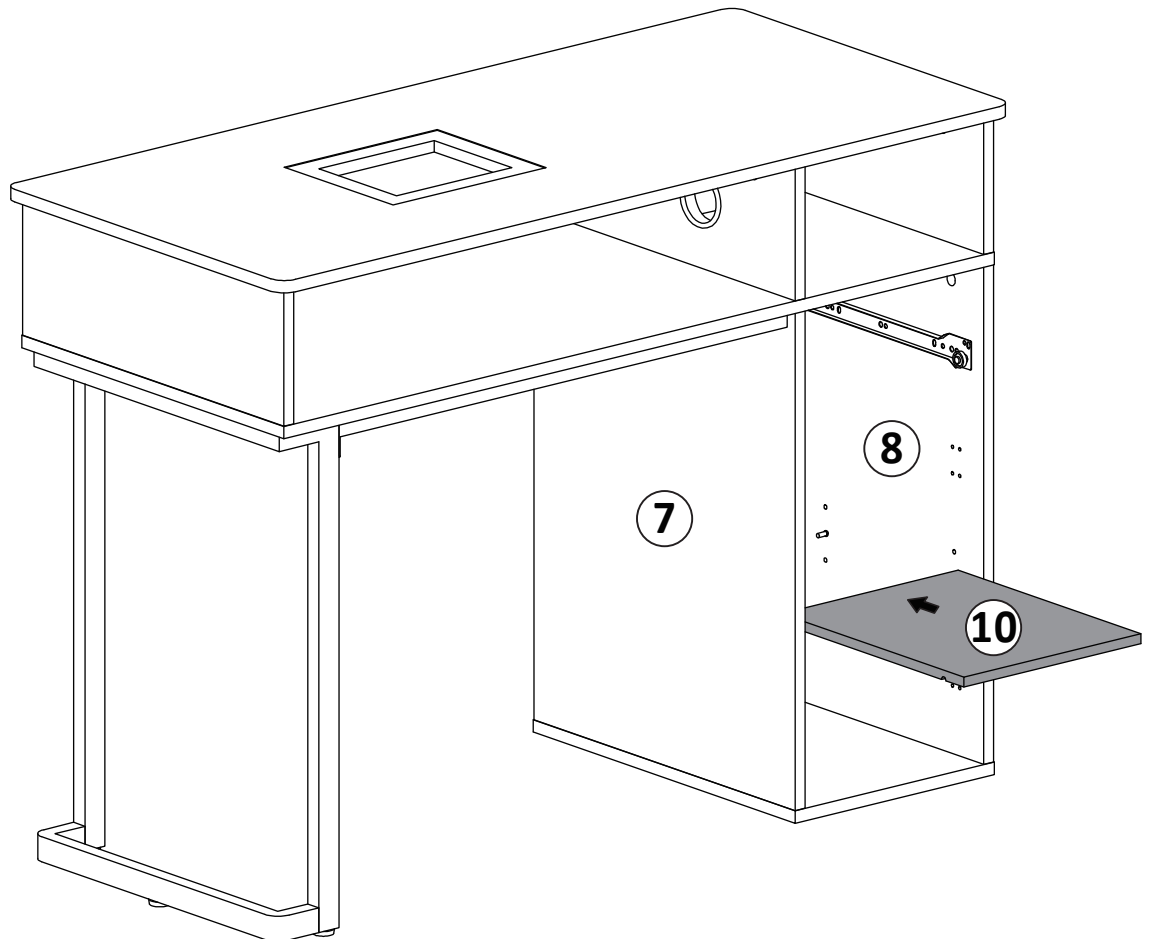

INSTALLATIONSANLEITUNG

Schritt 19

- ①⑨ X 1
- ① F X 4
- ① R X 2

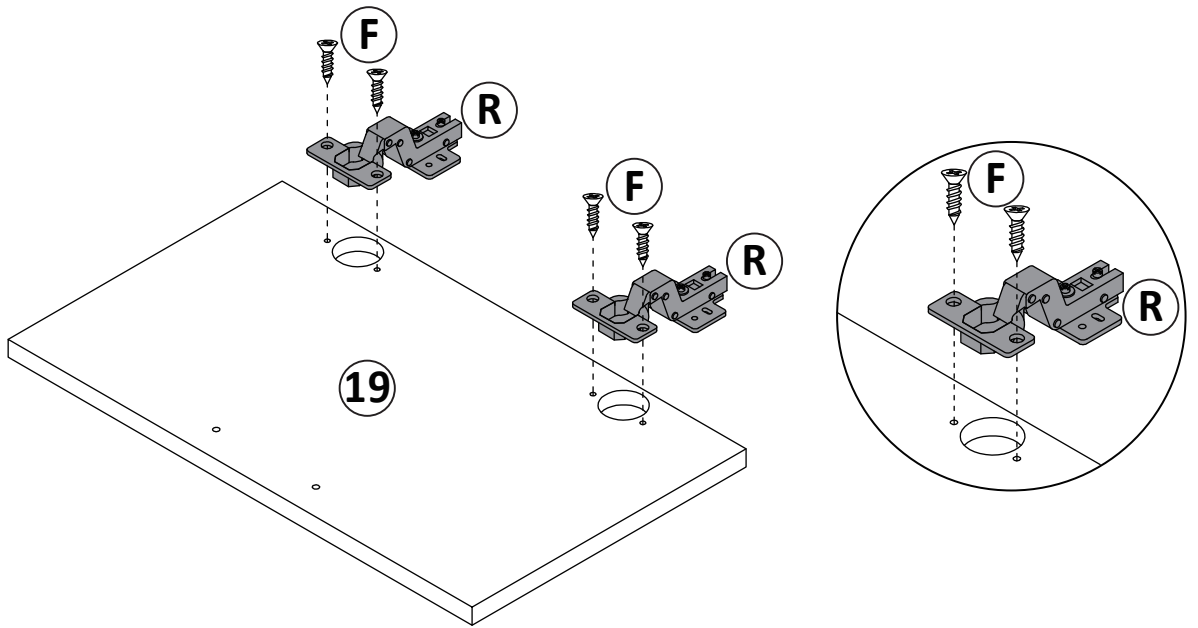

Schritt 20

- ① F X 8
- ① H X 1
- ① I X 2

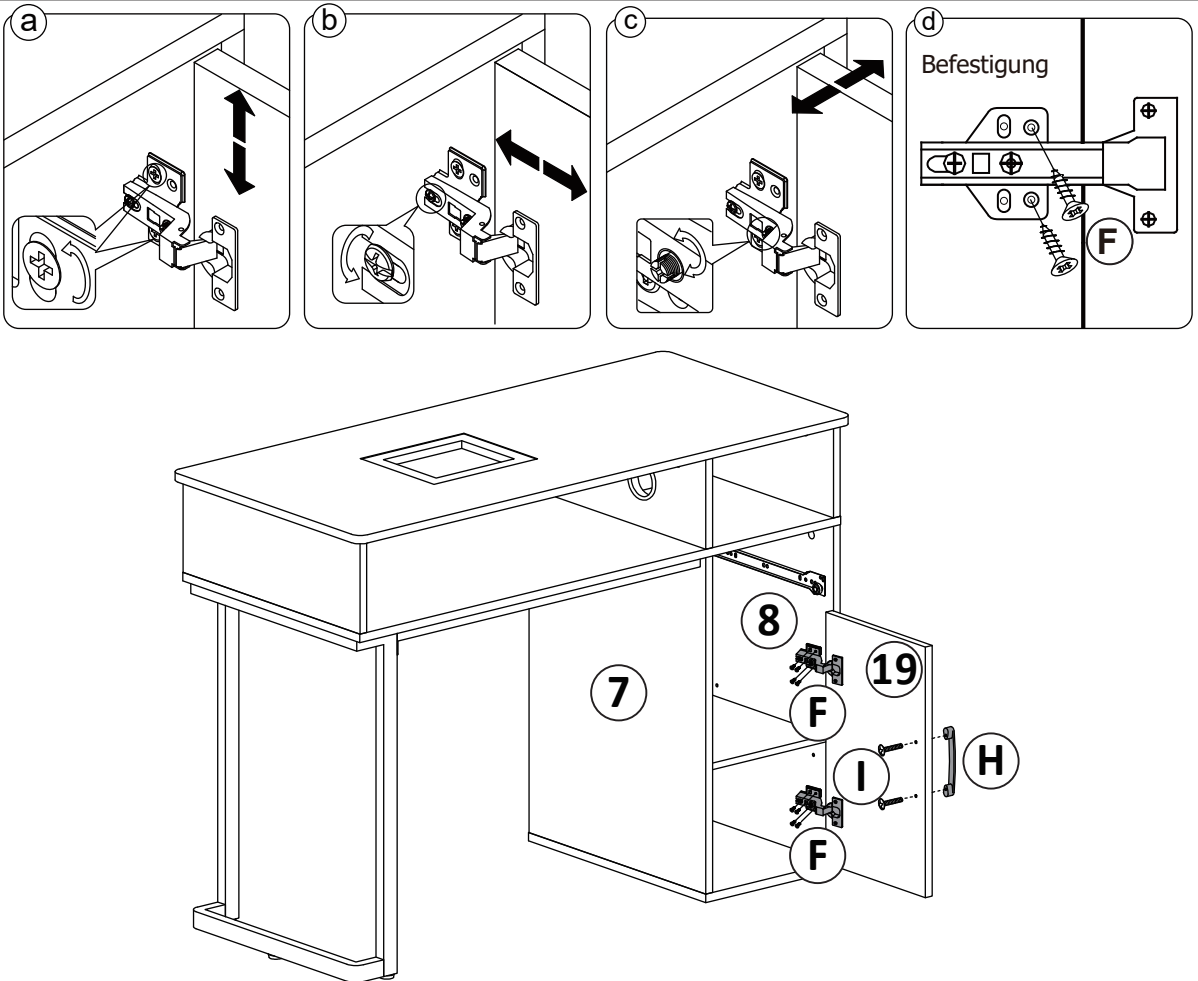

INSTALLATIONSANLEITUNG

Schritt 21

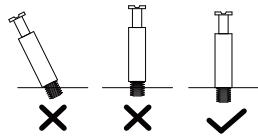

#A müssen vollständig verschraubt werden.

- ⑭ X 1
- ⑮ X 1
- ⑯ X 1
- ⑰ X 1
- ⑱ X 1
- Ⓐ X 4
- Ⓑ X 4
- Ⓒ X 4

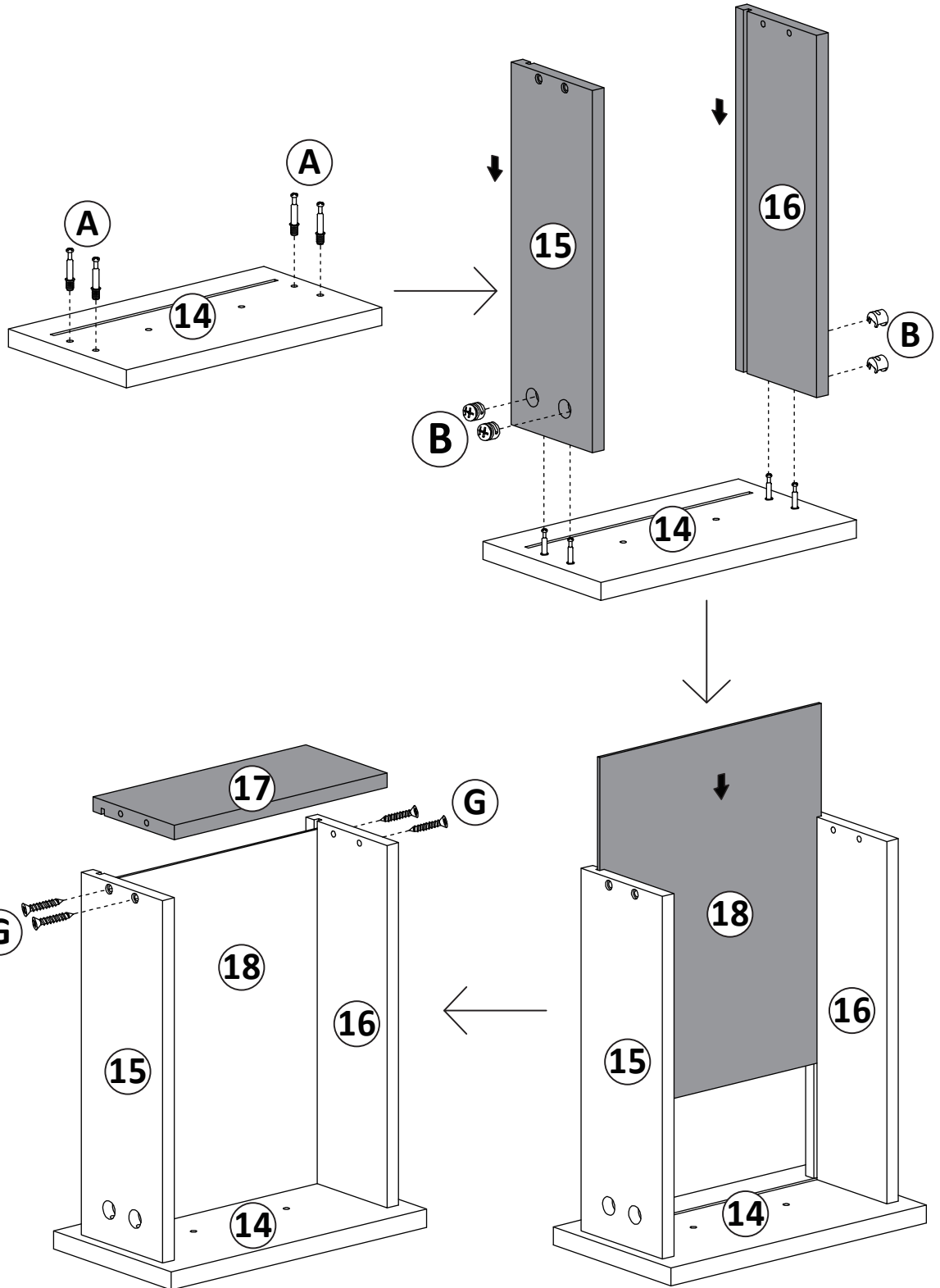

INSTALLATIONSANLEITUNG

Schritt 22

- ⓕ X 4
- ⓗ X 1
- ⓘ X 2
- ⒹⓁ X 1
- ⒹⓇ X 1

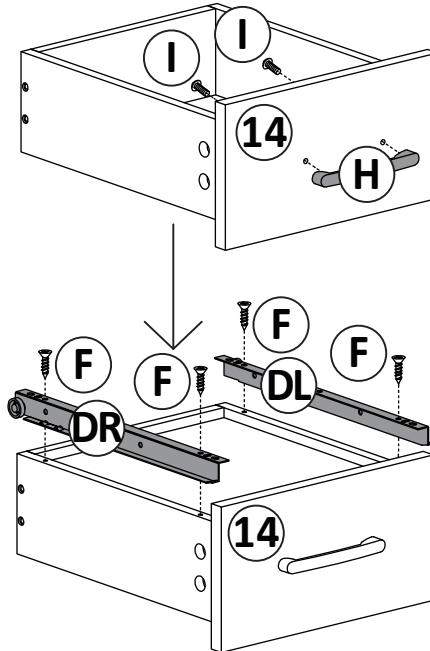
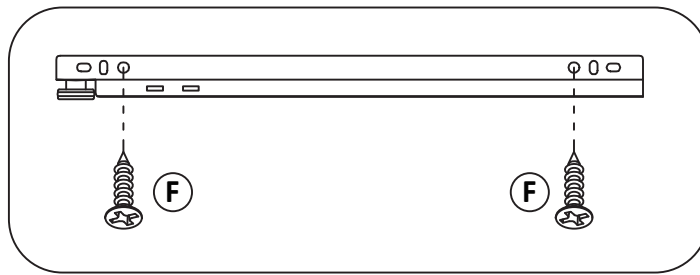

Schritt 23

- Ⓚ X 3

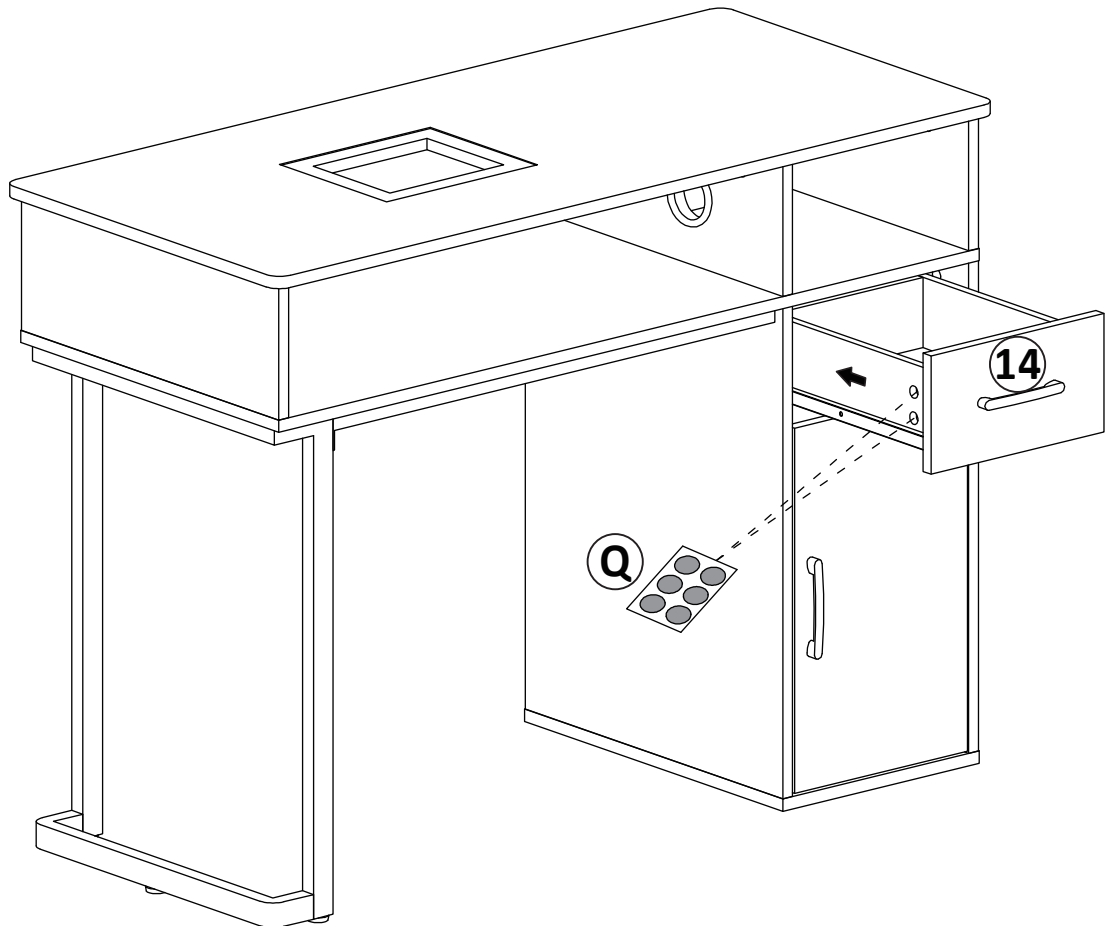

INSTALLATIONSANLEITUNG

Schritt 24

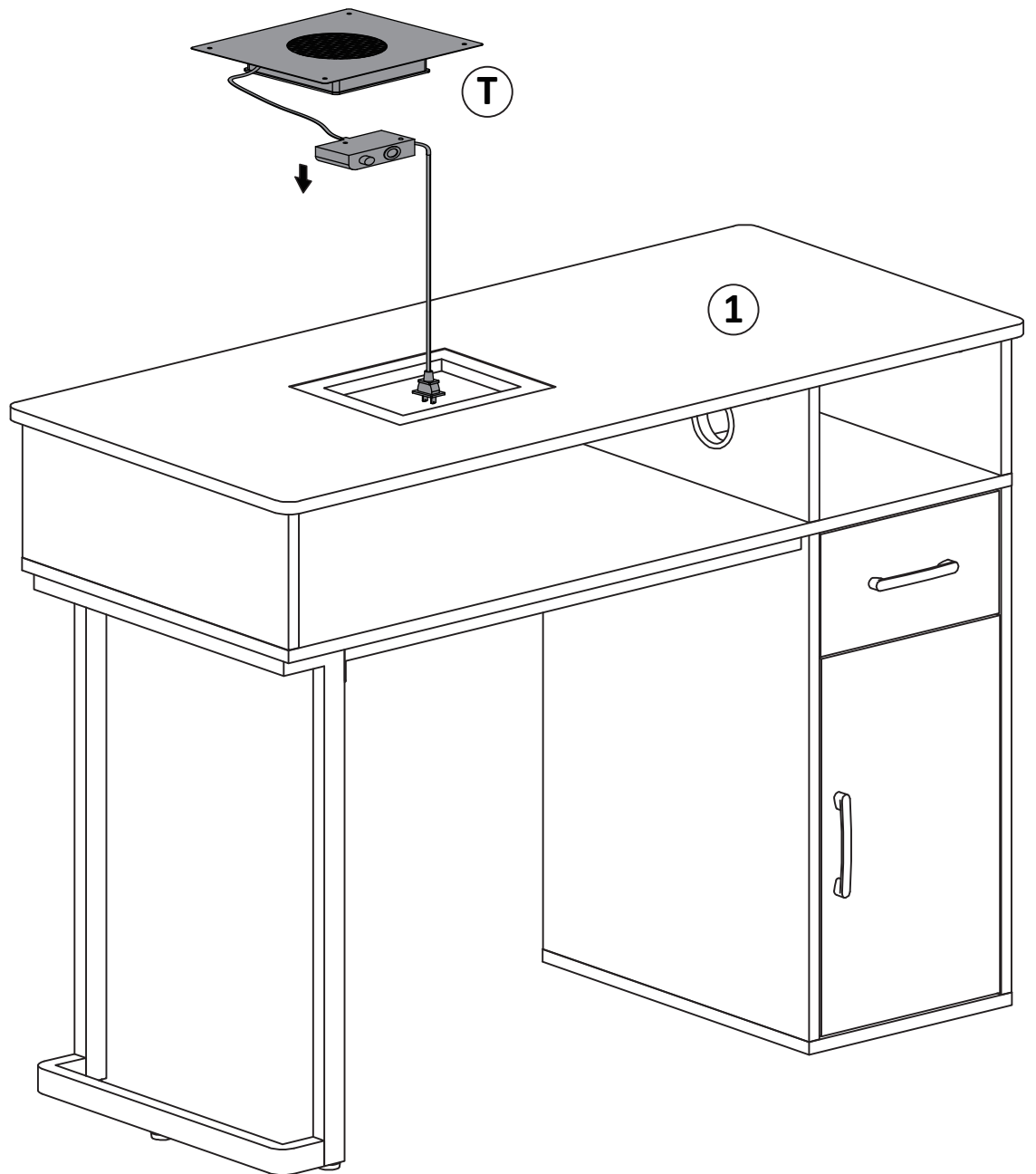

INSTALLATIONSANLEITUNG

Schritt 25

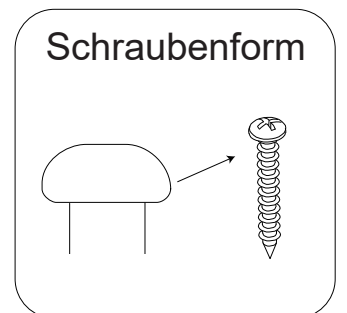
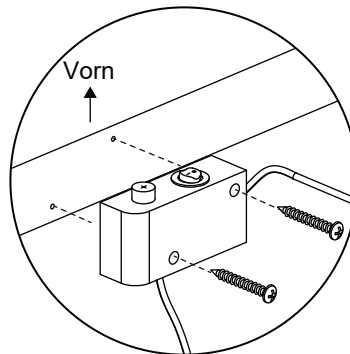
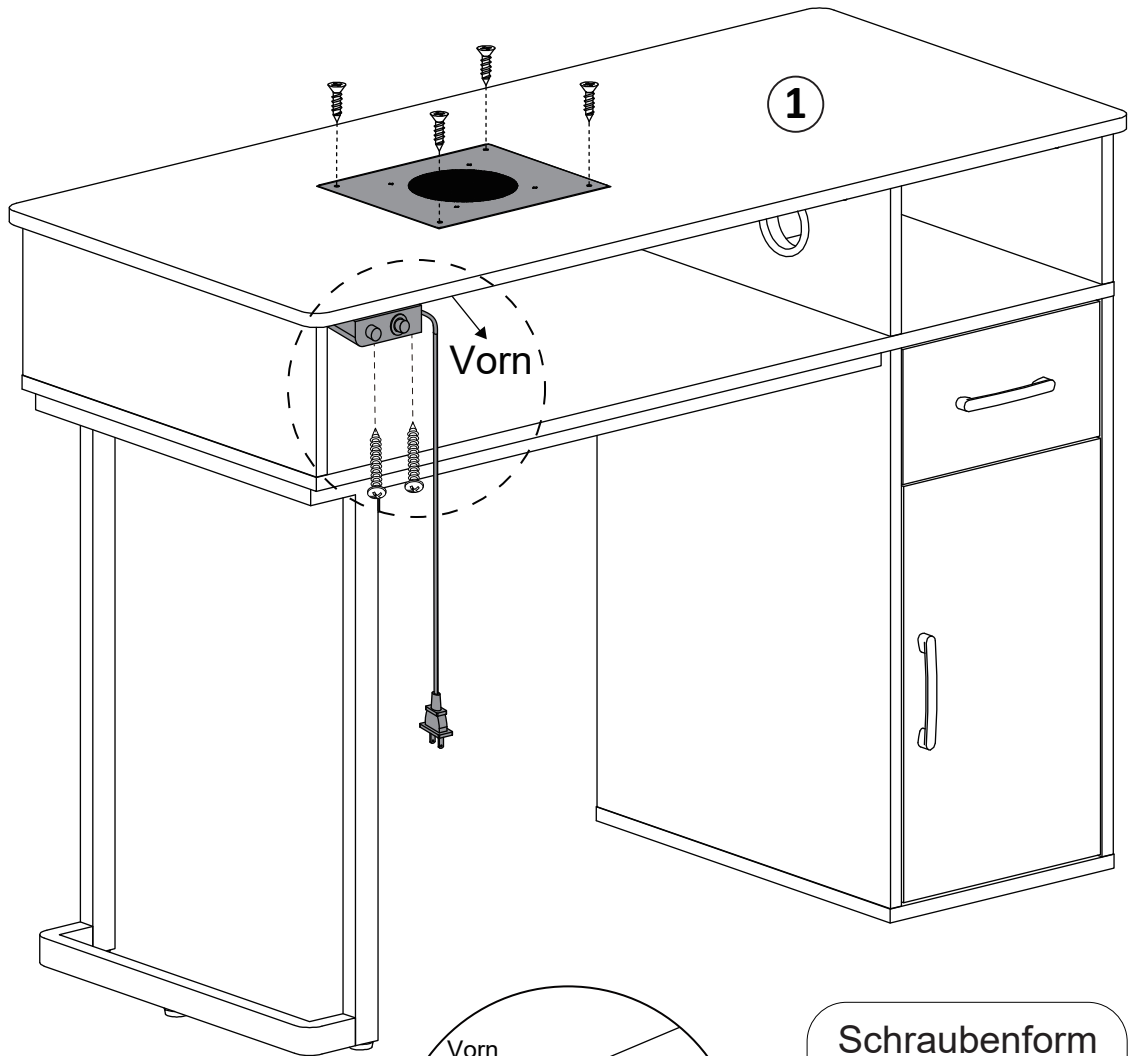
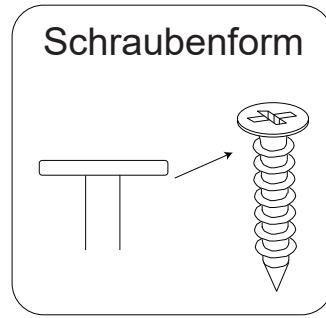
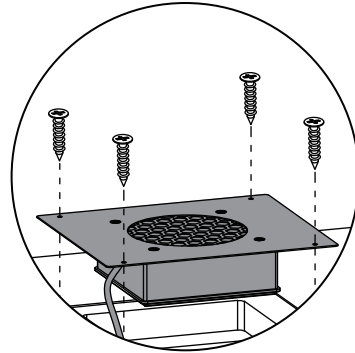

INSTALLATIONSANLEITUNG

Schritt 26

Ⓢ X 1

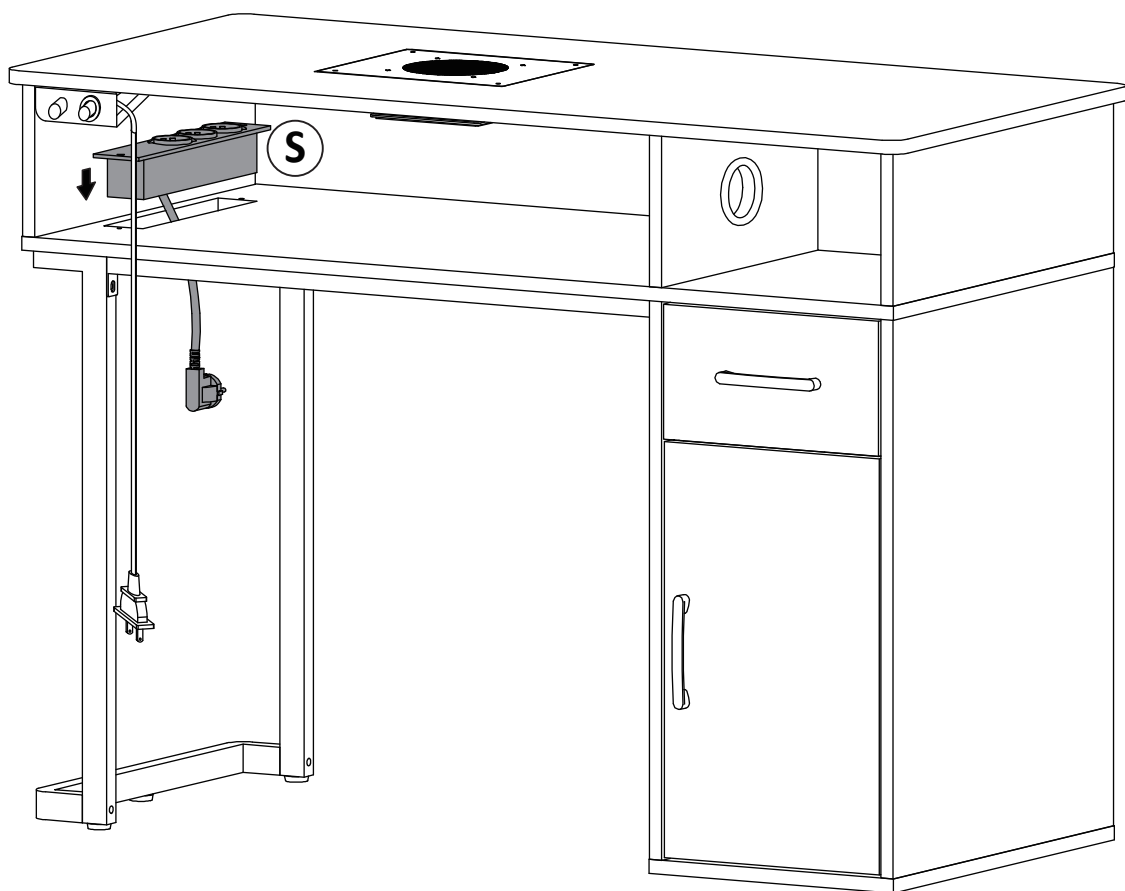

INSTALLATIONSANLEITUNG

Schritt 27

ⓕ X 2

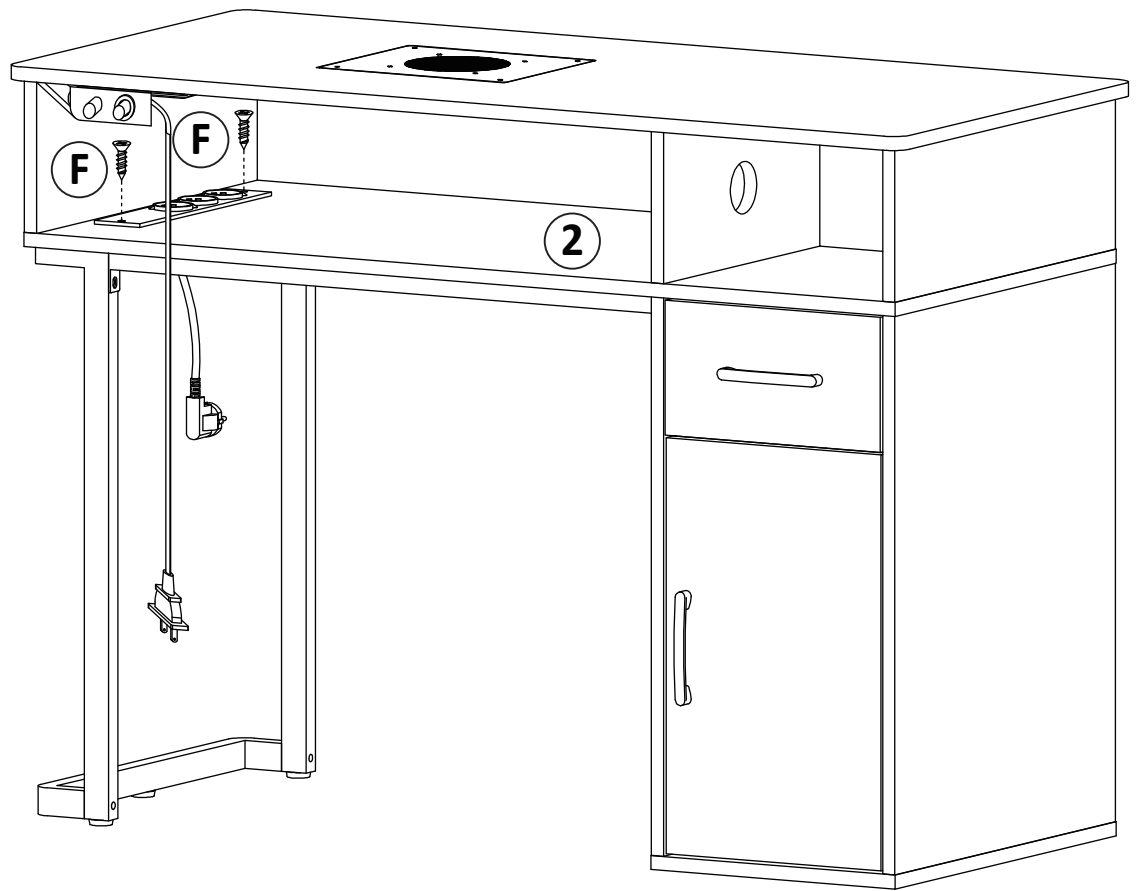

INSTALLATIONSANLEITUNG

Schritt 28

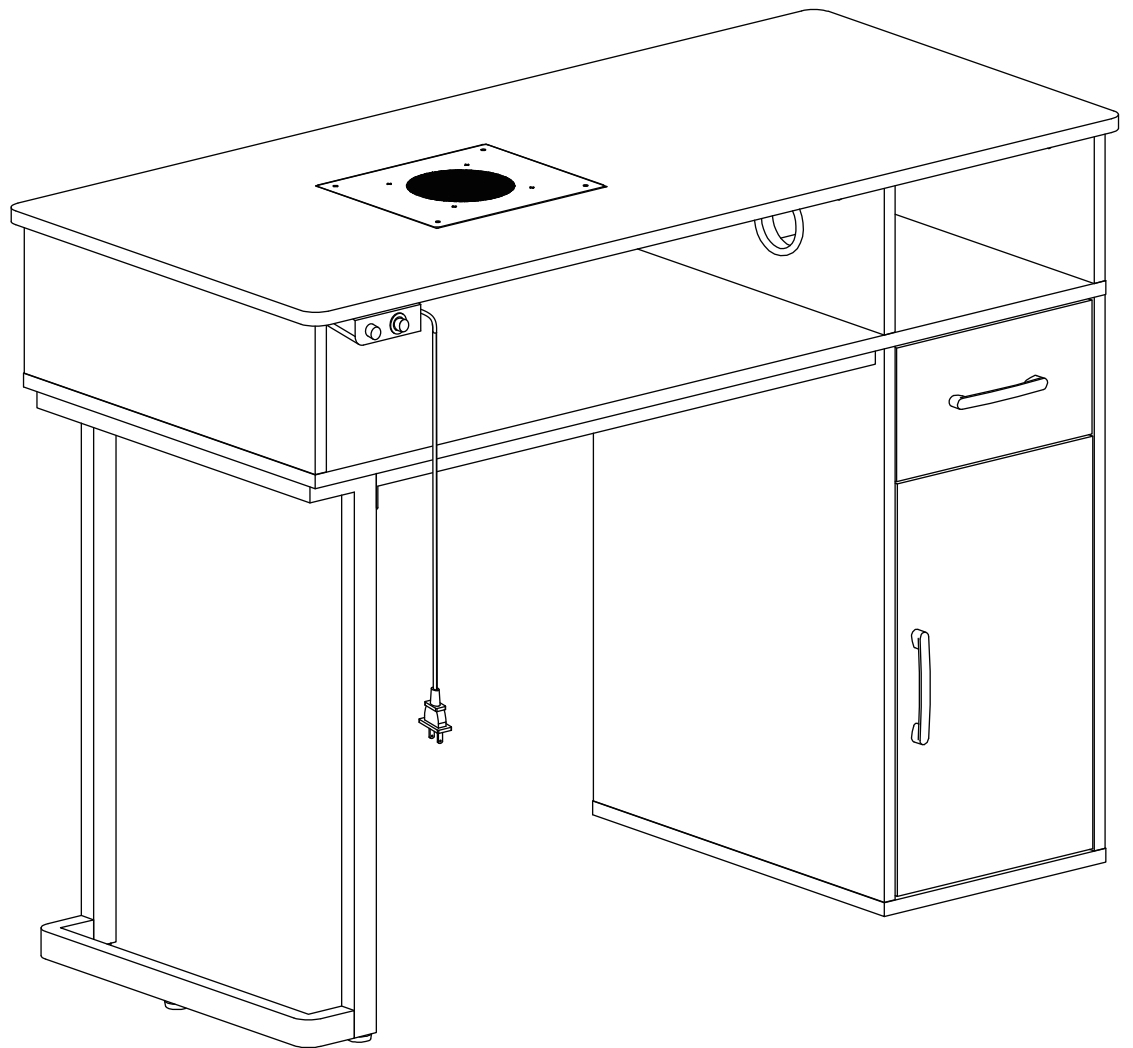

KUNDENDIENST

Ist das Produkt vollständig erhalten? Ist die Installation und Nutzung reibungslos verlaufen?

Wenn Sie Fragen oder Anregungen haben, setzen Sie sich bitte rechtzeitig mit uns in Verbindung. Wir werden unser Bestes versuchen, um das Problem zu lösen.

Haben Sie spezielle Anforderungen an Größe, Farbe, Stil, Material oder andere Aspekte Ihres Produkts?

Zögern Sie nicht, uns zu kontaktieren, wir verstehen Ihre Bedürfnisse gerne und bieten Ihnen bessere Produkte.

	0049-(0)21511561192
	pfillo.de@gmail.com (innerhalb 24h)
	Kreuzweg 60, 47809 Krefeld, Deutschland



BARBERPUB



Barberpub.de

Product Name: Nail table
Model: 6090-2491
Production Batch: 08429381088315
Country Origin: Made in China
Manufacturer: Pfillo GmbH
Address: Brehmstraße 56,
40239 Düsseldorf, Germany
E-Mail: info.de@newacmelc.com
Tel: 004921511561192



Pfillo GmbH
Brehmstraße 56, 40239 Düsseldorf, Germany
info.de@newacmelc.com
004921511561192

